

boracelik

ALL IN ONE
DISPLAY
SOLUTIONS

MATRIX 2134 CATALOG

boracelik

ALL IN ONE
DISPLAY SOLUTIONS

MATRIX 2134 CATALOG

ABOUT US

Our values are, Prioritization of safety, quality, and environment in; our all actions. To make our personnel internalize and practice the philosophy of constant improvement. To carry on relationships with our personnel and business partners based on honesty and standing trust. To prioritise cost reduction in our all processes. To complete a task in one go, on desired time and without any inaccuracy. To give weight to teamwork for the effective participation by providing trainings enhancing their knowledge and skill. to follow the developments about our sector and become the leader of innovations and implementations. To be a solution partner by getting involved in our customer's design studies. to be respectful to humanity and society.

STRONG CONNECTION WITH HIGH TECHNOLOGY

Abotut Us Founded in 1976, Bora Celik is a bespoke designer, manufacturer and supplier of showroom display panels, situated in Eskisehir, Turkey. Our main product lines consist of, but are not limited to, Ceramic display cabinets, Display panels, Door displays, Tile display stands, along with Tile, Stone, Marble and Mosaic displays. We also design and manufacture commercial areas and showrooms that cater to the ceramics and bathroom industries. Our strength comes from our custom design and unique production capabilities, ensuring that both our production and supply organisations are flexible enough to manufacture and deliver any volumes. In short, we can and will deliver any amount of product within the timescale required, without any order restrictions, with branding and packing being decided by our clients. Our highly skilled design team will ensure that all aspects of quality, dimensions and general design build meet your expectations, whilst providing a tailored and cost effective solution to your needs, when productivity is essential. Bora Celik is here for you, as a trustworthy supplier when you require comprehension, communication, research and service.

Who Are We Bora Celik's key success comes from its dynamic, innovative, entrepreneur structure and harmony energy in its own up to now and so it has been. Our company which has 11.000 squer meter area and has also 650 m2 in İstanbul. Bora Celik architechtural retai desing concentrates on "exhibition design as converted developed notions for retail strategy into different space types segmetation and architechtural strcture by creatng concept visla designs.

What We Are Doing Design (corporate identity - store - exhibition etc.)
Performance (store concept
turn-key/domestic- foreign)
Prodiction (mass production of showroom equipment/custom design production)
Frontal design and aplication (sidding/advertising board applicatinon etc.)
Exhibition design+application (domestic foregin)

How we are doing Concept store plan Sketch plan of retail area 3D Concept store design sketches of 3D brand experience- general environment furniture & feature areas transaction/domonstration and promotion zones. Shop front showing store signage & winow treatment, Promo areas ,3D Concept store design sketch of future zones Feature entrence finishes proçosals for flooring ceiling lighting wall finishes , Element detailing to crate a comprehensive design manula, based on an "ideal" layout. Working drawings (design intent) of all elements & feature areas
Model Store plans and elevations based on a standart "ideal" location

Showroom & Fair Design Bora Celik provides to its clients a comprehensive service focusing on the showroom and fair design with the highest technological applicatio"n and creative, highly skilled team of designers & technicians.

Research - Development Research and development team plays a critical role in the innovation process of displays. Bora Celik makes essential investment in technology and future capabilities which is transformed into new products, processes, and services.

Display Systems Harmonized With Metal and Wood

Bora Celik manufactures display systems harmonized with metal and wood using a wide variety of materials. From prototype to completion, we are proud of our proven track record. We manufacture products to the highest quality and dispatch on time. Bora Celik' s key success comes from its dynamic, innovative, entrepreneur structure and energy in its own up to now and so it has been.

Printing Bora Celik offers to its clients large format digital printing with high tech machine HP Latex 3010, offset printing with high quality.

Packing and Logistics As Bora Celik, we are paying special attention to the packing in order to protect the goods and enable an easy loading & unloading without any damages or difficulties. Our logistics team handles carefully all aspects of the process, assisting you also in every step of the custom procedures and providing all relevant documentation convenient to each countries formalities and regulations.

After Sell Service Bora Celik builds a long-term relationship with its customers, earn their loyalty and keep their business with letting them online services and with providing repairs, refunds and warranties.

Terms of Sale Bora Celik reserves the right to make changes to the material or design of the product if necessary for easy usage and stability.

In this catalogue, some of the products shows accessories and tiles, these are not included in the sale.

Terms of Warranty Bora Celik warrants that products shall be delivered free from defects in material and workmanship and in accordance with any mutually agreed specifications. The warranty for products shall expire 1year from the shipment date of the products to emphasize the high quality standard. After the expiration of this 1 year period seller shall no longer accept warranty claims and all obligations for warranty shall terminate.

MATRIX

Bora Çelik's Matrix System is the perfect solution for those who are looking for a fast and easy fitting out of showrooms and sales points, cheap and durable. Thanks to its modular walls, Matrix allows the interior design and fitting out of any space in a short time, without troubles and with the Maximum cleaning. A custom-made system, with easy interlocking assembly, where no cuts are needed, who allows to create, modify, enlarge and update any space without calling o professional. All Matrix elements can be personalized in colors, materials, finishes, to be always in harmony with the coordinate image of the showroom.



MATRIX

Modifiable at any time



Example of composition



- 1 metal frame
- 2 inner prf T
- 3 inner prf L
- 4 panel
- 5 closing element

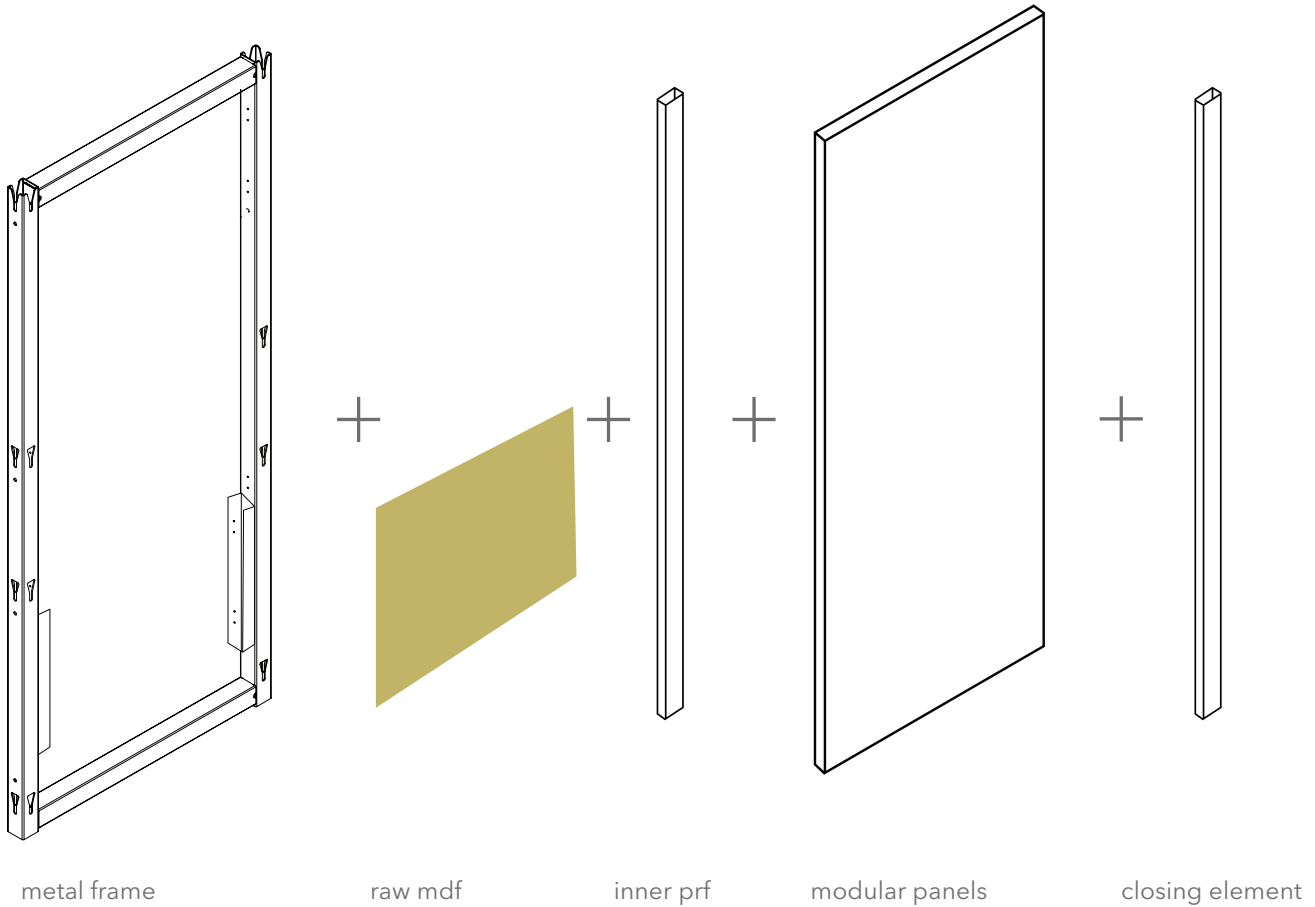

Choose your dimensions

metal frame
width, height
variation

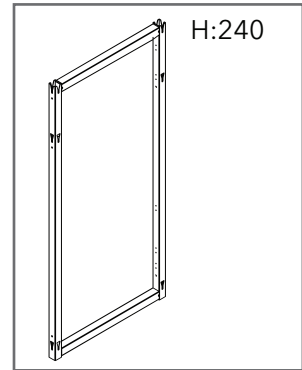
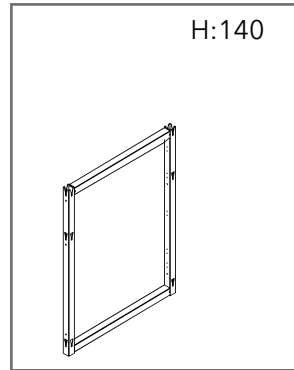
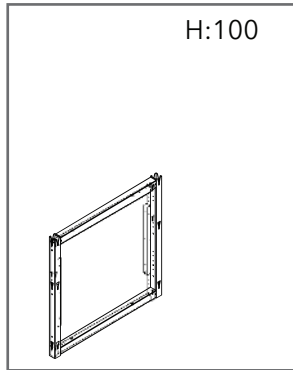
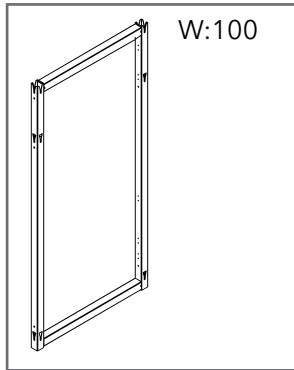
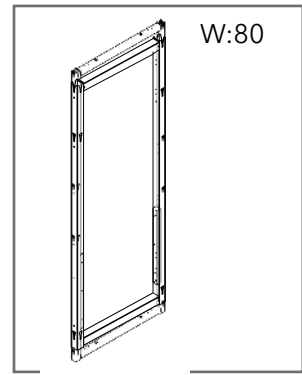
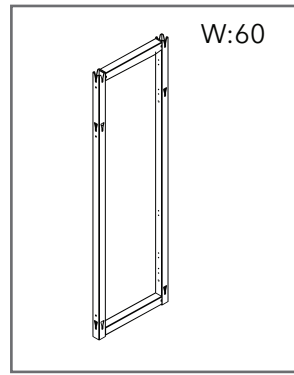
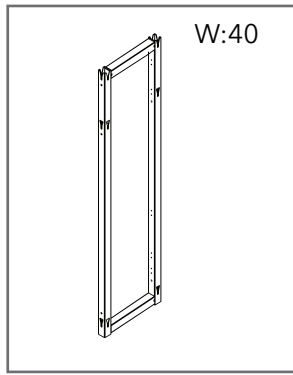

inner prf
width
variation

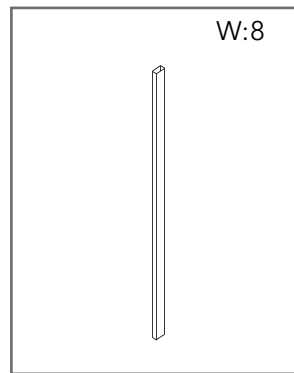
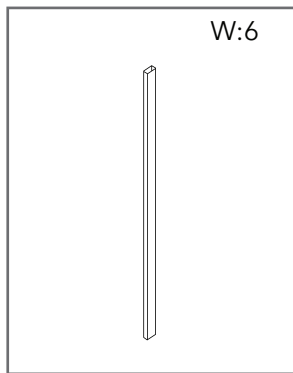

modular panels
variation

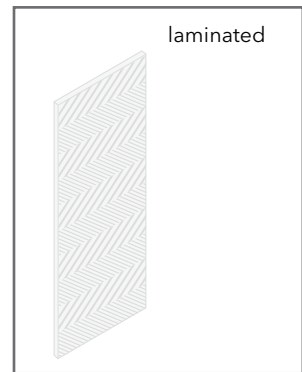
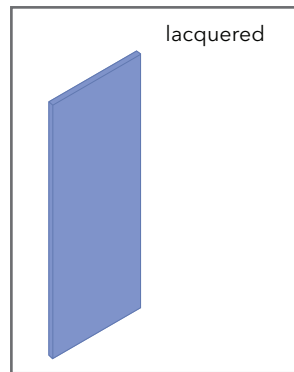
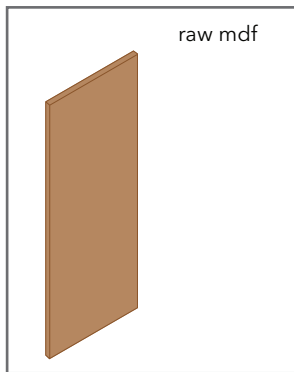

closing element
variation

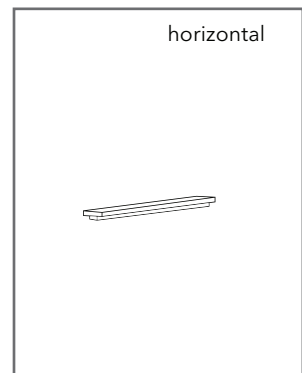
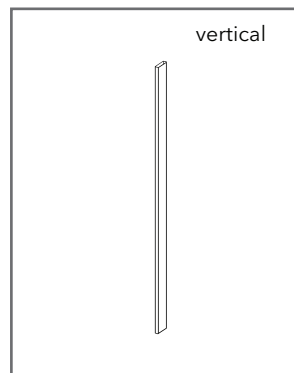

MATRIX CONSTRUCTION

BM, BW

BW Series
BM Series

CONSTRUCTION

CONSTRUCTION
CONSTRUCTION

BW WALL METAL FRAME

BW001D01

| Code | Stand Size | Panels | Panel Size | Max | Packing | Total |
|----------|------------|--------|------------|-----|---------|-------|
| | Cm | Qty | Cm | Kg | Cm | Kg |
| BW001D01 | 40*226*4 | - | - | - | - | - |

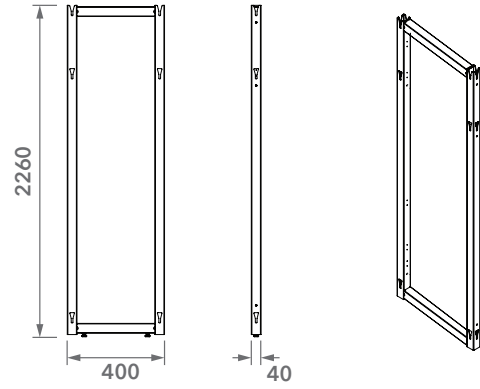

BW002D01

| Code | Stand Size | Panels | Panel Size | Max | Packing | Total |
|----------|------------|--------|------------|-----|---------|-------|
| | Cm | Qty | Cm | Kg | Cm | Kg |
| BW002D01 | 60*226*4 | - | - | - | - | - |

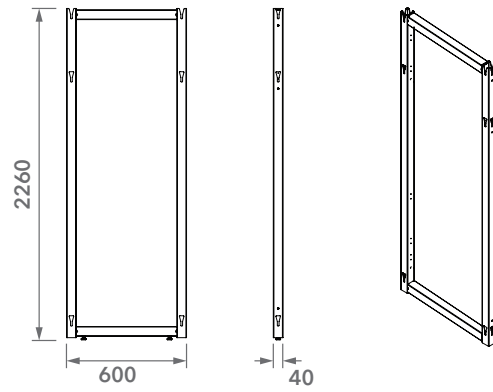

BW003D01

| Code | Stand Size | Panels | Panel Size | Max | Packing | Total |
|----------|------------|--------|------------|-----|---------|-------|
| | Cm | Qty | Cm | Kg | Cm | Kg |
| BW003D01 | 80*226*4 | - | - | - | - | - |

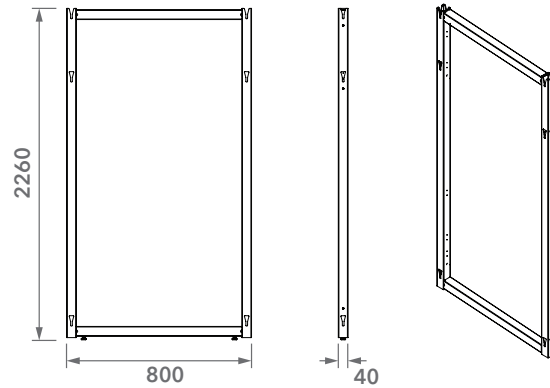

BW004D01

| Code | Stand Size | Panels | Panel Size | Max | Packing | Total |
|----------|------------|--------|------------|-----|---------|-------|
| | Cm | Qty | Cm | Kg | Cm | Kg |
| BW004D01 | 100*226*4 | - | - | - | - | - |

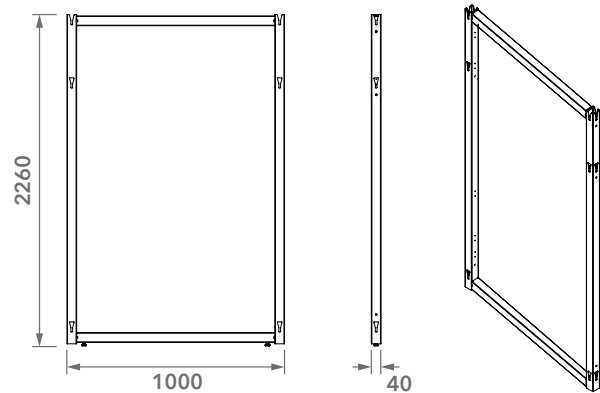

BW WALL METAL FRAME

BW001D02

| Code | Stand Size | Panels | Panel Size | Max | Packing | Total |
|----------|------------|--------|------------|-----|---------|-------|
| | Cm | Qty | Cm | Kg | Cm | Kg |
| BW001D02 | 40*138*4 | - | - | - | - | - |

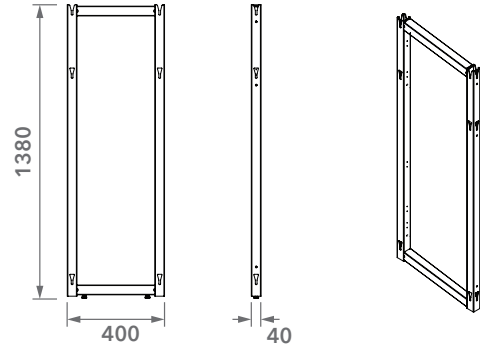

BW002D02

| Code | Stand Size | Panels | Panel Size | Max | Packing | Total |
|----------|------------|--------|------------|-----|---------|-------|
| | Cm | Qty | Cm | Kg | Cm | Kg |
| BW002D01 | 60*138*4 | - | - | - | - | - |

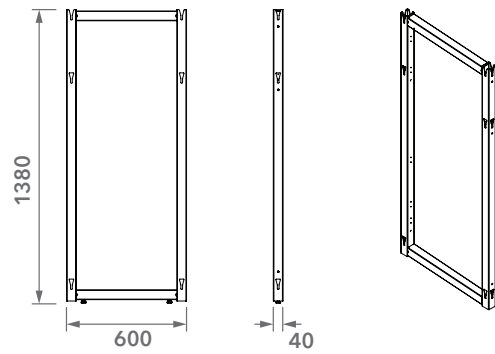

BW003D02

| Code | Stand Size | Panels | Panel Size | Max | Packing | Total |
|----------|------------|--------|------------|-----|---------|-------|
| | Cm | Qty | Cm | Kg | Cm | Kg |
| BW003D01 | 80*138*4 | - | - | - | - | - |

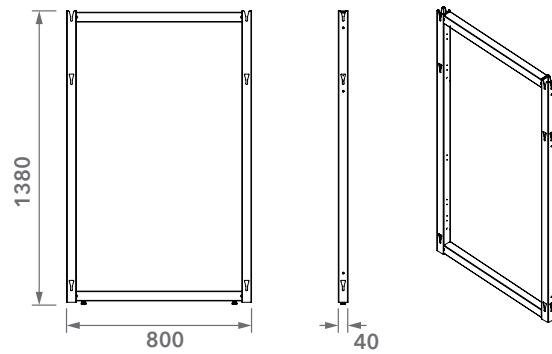

BW004D02

| Code | Stand Size | Panels | Panel Size | Max | Packing | Total |
|----------|------------|--------|------------|-----|---------|-------|
| | Cm | Qty | Cm | Kg | Cm | Kg |
| BW004D04 | 100*138*4 | - | - | - | - | - |

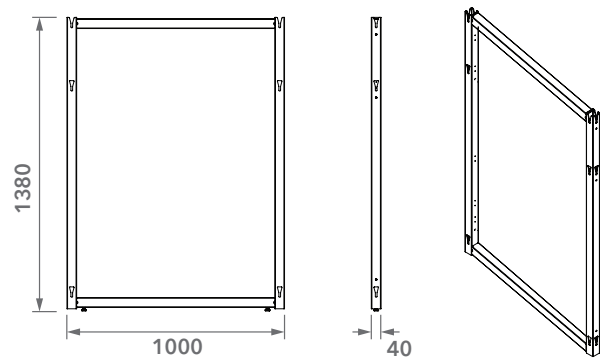

BW WALL METAL FRAME

BW001D03

| Code | Stand Size | Panels | Panel Size | Max | Packing | Total |
|----------|------------|--------|------------|-----|---------|-------|
| | Cm | Qty | Cm | Kg | Cm | Kg |
| BW001D01 | 40*98*4 | - | - | - | - | - |

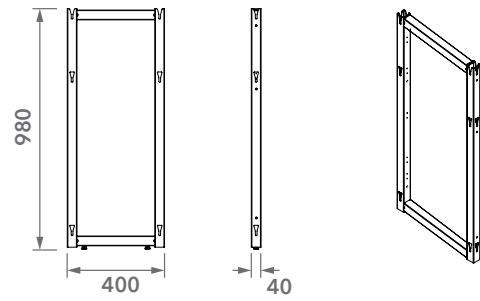

BW002D03

| Code | Stand Size | Panels | Panel Size | Max | Packing | Total |
|----------|------------|--------|------------|-----|---------|-------|
| | Cm | Qty | Cm | Kg | Cm | Kg |
| BW002D03 | 60*98*4 | - | - | - | - | - |

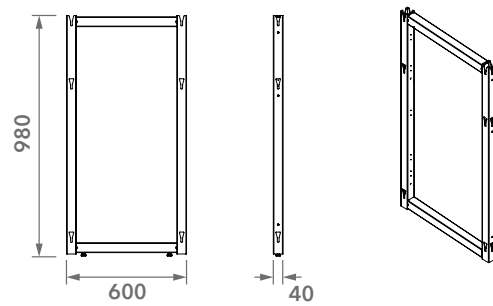

BW003D03

| Code | Stand Size | Panels | Panel Size | Max | Packing | Total |
|----------|------------|--------|------------|-----|---------|-------|
| | Cm | Qty | Cm | Kg | Cm | Kg |
| BW003D03 | 80*98*4 | - | - | - | - | - |

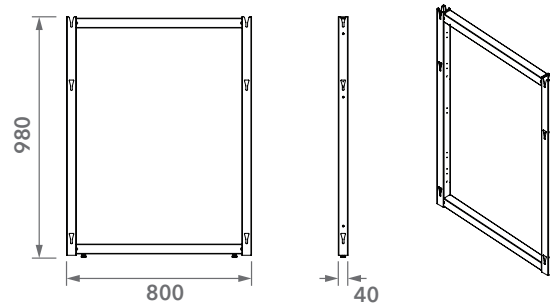

BW004D03

| Code | Stand Size | Panels | Panel Size | Max | Packing | Total |
|----------|------------|--------|------------|-----|---------|-------|
| | Cm | Qty | Cm | Kg | Cm | Kg |
| BW004D03 | 100*98*4 | - | - | - | - | - |

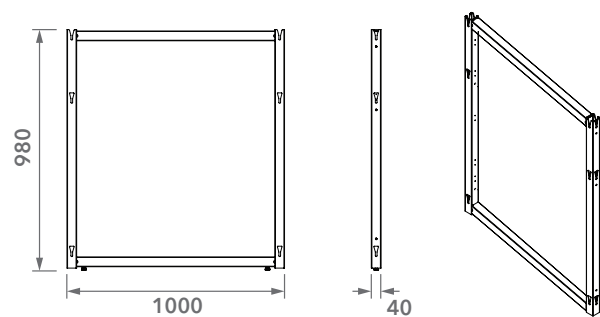

BM ISLAND METAL FRAME

BM001D01

| Code | Stand Size | Panels | Panel Size | Max | Packing | Total |
|----------|------------|--------|------------|-----|---------|-------|
| | Cm | Qty | Cm | Kg | Cm | Kg |
| BM001D01 | 40*226*4 | - | - | - | - | - |

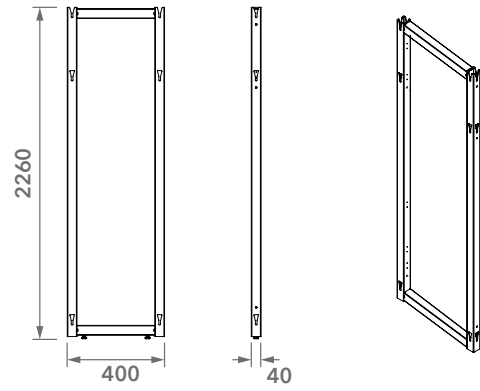

BM002D01

| Code | Stand Size | Panels | Panel Size | Max | Packing | Total |
|----------|------------|--------|------------|-----|---------|-------|
| | Cm | Qty | Cm | Kg | Cm | Kg |
| BM002D01 | 60*226*4 | - | - | - | - | - |

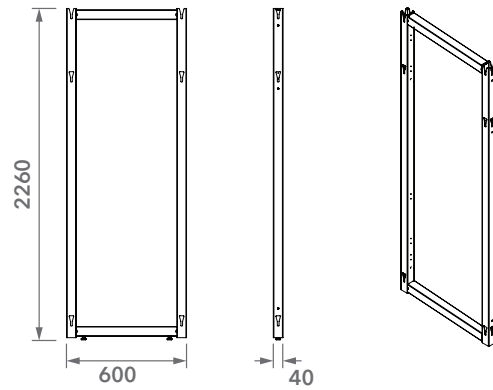

BM003D01

| Code | Stand Size | Panels | Panel Size | Max | Packing | Total |
|----------|------------|--------|------------|-----|---------|-------|
| | Cm | Qty | Cm | Kg | Cm | Kg |
| BM003D01 | 80*226*4 | - | - | - | - | - |

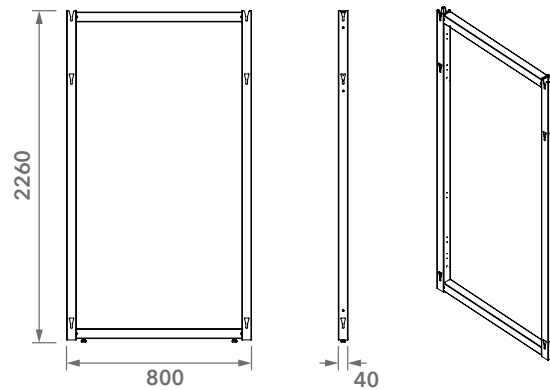

BM004D01

| Code | Stand Size | Panels | Panel Size | Max | Packing | Total |
|----------|------------|--------|------------|-----|---------|-------|
| | Cm | Qty | Cm | Kg | Cm | Kg |
| BM004D01 | 100*226*4 | - | - | - | - | - |

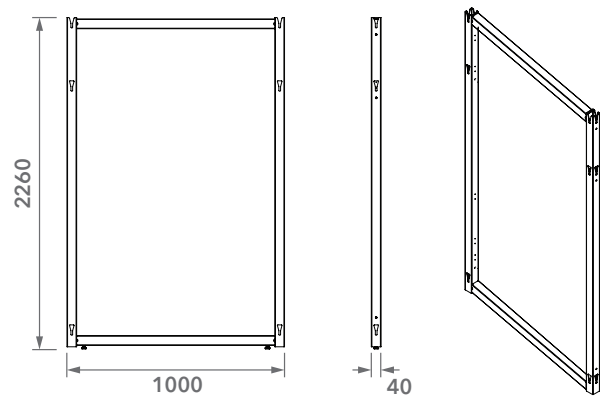

BM ISLAND METAL FRAME

BM001D02

| Code | Stand Size | Panels | Panel Size | Max | Packing | Total |
|----------|------------|--------|------------|-----|---------|-------|
| | Cm | Qty | Cm | Kg | Cm | Kg |
| BM001D02 | 40*138*4 | - | - | - | - | - |

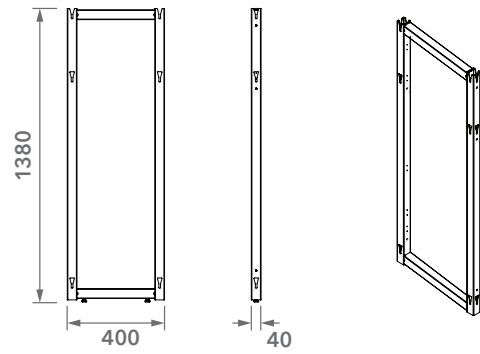

BM002D02

| Code | Stand Size | Panels | Panel Size | Max | Packing | Total |
|----------|------------|--------|------------|-----|---------|-------|
| | Cm | Qty | Cm | Kg | Cm | Kg |
| BM002D01 | 60*138*4 | - | - | - | - | - |

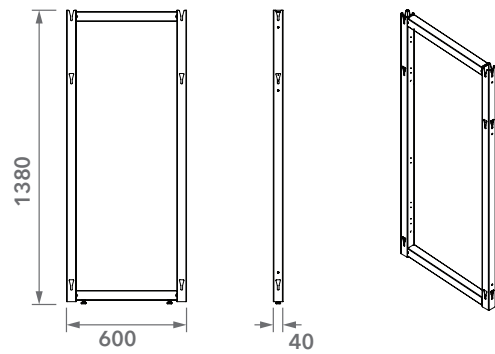

BM003D02

| Code | Stand Size | Panels | Panel Size | Max | Packing | Total |
|----------|------------|--------|------------|-----|---------|-------|
| | Cm | Qty | Cm | Kg | Cm | Kg |
| BM003D01 | 80*138*4 | - | - | - | - | - |

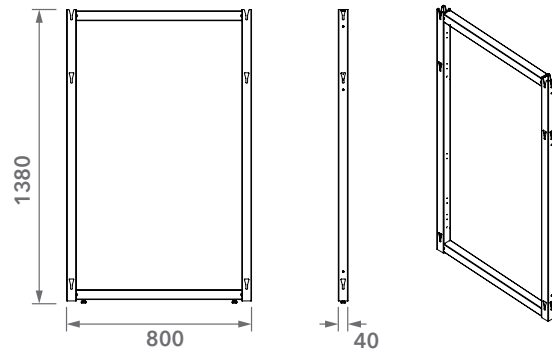

BM004D02

| Code | Stand Size | Panels | Panel Size | Max | Packing | Total |
|----------|------------|--------|------------|-----|---------|-------|
| | Cm | Qty | Cm | Kg | Cm | Kg |
| BW004D04 | 100*138*4 | - | - | - | - | - |

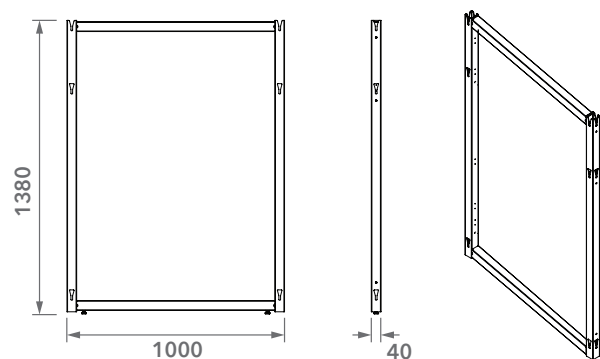

BM ISLAND METAL FRAME

BM001D03

| Code | Stand Size | Panels | Panel Size | Max | Packing | Total |
|----------|------------|--------|------------|-----|---------|-------|
| | Cm | Qty | Cm | Kg | Cm | Kg |
| BM001D01 | 40*98*4 | - | - | - | - | - |

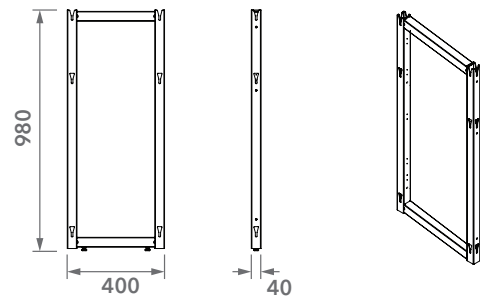

BM002D03

| Code | Stand Size | Panels | Panel Size | Max | Packing | Total |
|----------|------------|--------|------------|-----|---------|-------|
| | Cm | Qty | Cm | Kg | Cm | Kg |
| BM002D03 | 60*98*4 | - | - | - | - | - |

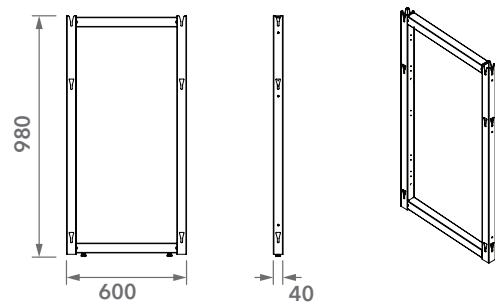

BM003D03

| Code | Stand Size | Panels | Panel Size | Max | Packing | Total |
|----------|------------|--------|------------|-----|---------|-------|
| | Cm | Qty | Cm | Kg | Cm | Kg |
| BW003D03 | 80*98*4 | - | - | - | - | - |

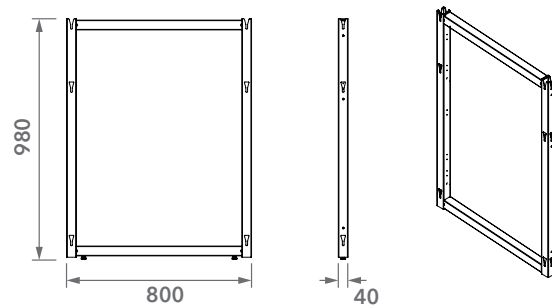

BM004D03

| Code | Stand Size | Panels | Panel Size | Max | Packing | Total |
|----------|------------|--------|------------|-----|---------|-------|
| | Cm | Qty | Cm | Kg | Cm | Kg |
| BW004D03 | 100*98*4 | - | - | - | - | - |

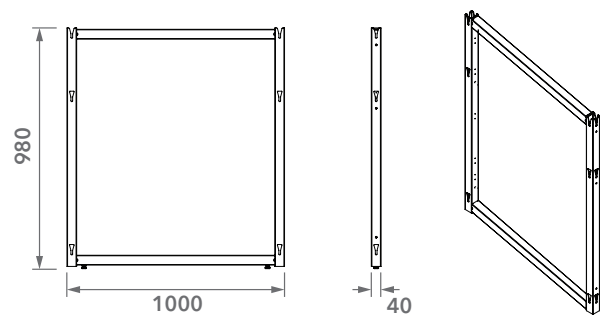

BM MODULAR WALLS-MDF

BM001F01

| Code | Stand Size | Panels | Panel Size | Max | Packing | Total |
|----------|------------|--------|------------|-----|---------|-------|
| | Cm | Qty | Cm | Kg | Cm | Kg |
| BM001F01 | 40*240 | - | - | - | - | - |
| BM002F01 | 44*240 | - | - | - | - | - |
| BM003F01 | 46*240 | - | - | - | - | - |
| BM004F01 | 48*240 | - | - | - | - | - |

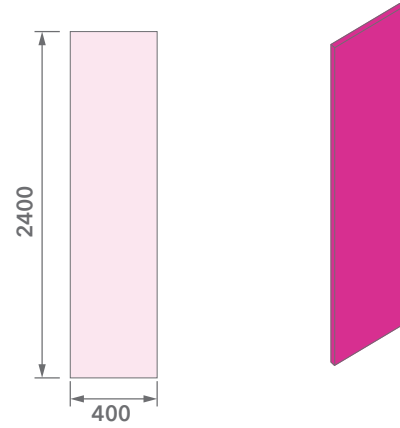

BM005F01

| Code | Stand Size | Panels | Panel Size | Max | Packing | Total |
|----------|------------|--------|------------|-----|---------|-------|
| | Cm | Qty | Cm | Kg | Cm | Kg |
| BM005F01 | 60*240 | - | - | - | - | - |
| BM006F01 | 64*240 | - | - | - | - | - |
| BM007F01 | 66*240 | - | - | - | - | - |
| BM008F01 | 68*240 | - | - | - | - | - |

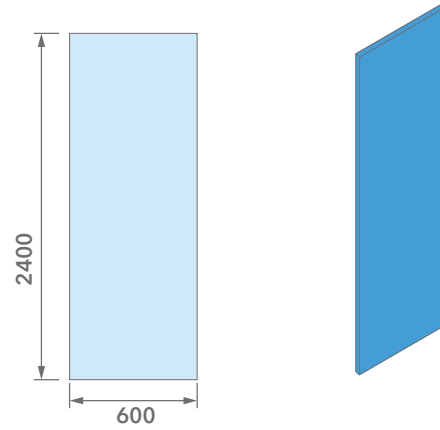

BM009F01

| Code | Stand Size | Panels | Panel Size | Max | Packing | Total |
|-----------|------------|--------|------------|-----|---------|-------|
| | Cm | Qty | Cm | Kg | Cm | Kg |
| BM009F01 | 80*240 | - | - | - | - | - |
| BM0010F01 | 84*240 | - | - | - | - | - |
| BM0011F01 | 86*240 | - | - | - | - | - |
| BM0012F01 | 88*240 | - | - | - | - | - |

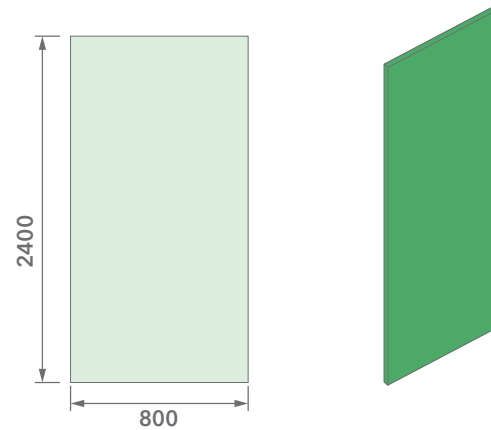

BM013F01

| Code | Stand Size | Panels | Panel Size | Max | Packing | Total |
|----------|------------|--------|------------|-----|---------|-------|
| | Cm | Qty | Cm | Kg | Cm | Kg |
| BM013F01 | 100*240 | - | - | - | - | - |
| BM014F01 | 104*240 | - | - | - | - | - |
| BM015F01 | 106*240 | - | - | - | - | - |
| BM016F01 | 108*240 | - | - | - | - | - |

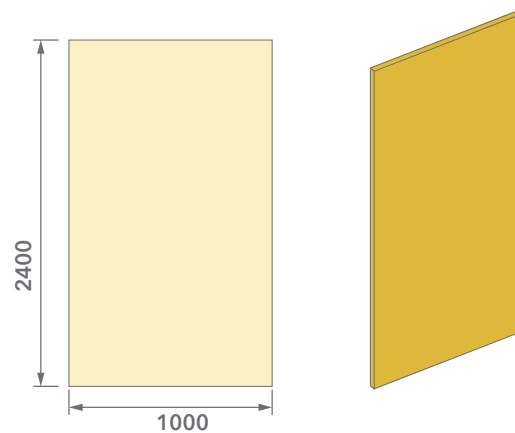

BM MODULAR WALLS-MDF

BM001F02

| Code | Stand Size | Panels | Panel Size | Max | Packing | Total |
|----------|------------|--------|------------|-----|---------|-------|
| | Cm | Qty | Cm | Kg | Cm | Kg |
| BM001F02 | 40*140 | - | - | - | - | - |
| BM002F02 | 44*140 | - | - | - | - | - |
| BM003F02 | 46*140 | - | - | - | - | - |
| BM004F02 | 48*140 | - | - | - | - | - |

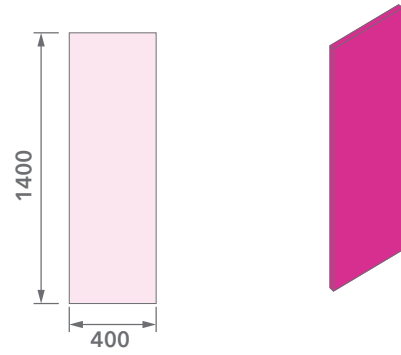

BM005F02

| Code | Stand Size | Panels | Panel Size | Max | Packing | Total |
|----------|------------|--------|------------|-----|---------|-------|
| | Cm | Qty | Cm | Kg | Cm | Kg |
| BM005F02 | 60*140 | - | - | - | - | - |
| BM006F02 | 64*140 | - | - | - | - | - |
| BM007F02 | 66*140 | - | - | - | - | - |
| BM008F02 | 68*140 | - | - | - | - | - |

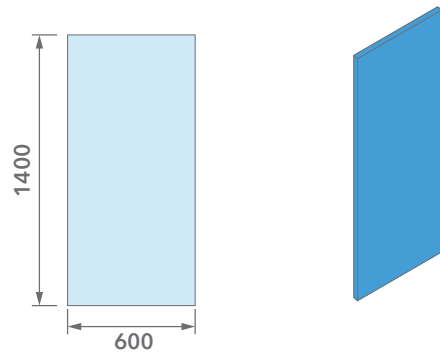

BM009F02

| Code | Stand Size | Panels | Panel Size | Max | Packing | Total |
|-----------|------------|--------|------------|-----|---------|-------|
| | Cm | Qty | Cm | Kg | Cm | Kg |
| BM009F02 | 80*140 | - | - | - | - | - |
| BM0010F02 | 84*140 | - | - | - | - | - |
| BM0011F02 | 86*140 | - | - | - | - | - |
| BM0012F02 | 88*140 | - | - | - | - | - |

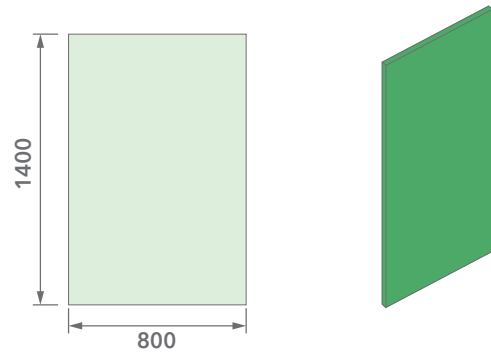

BM013F02

| Code | Stand Size | Panels | Panel Size | Max | Packing | Total |
|----------|------------|--------|------------|-----|---------|-------|
| | Cm | Qty | Cm | Kg | Cm | Kg |
| BM013F02 | 100*140 | - | - | - | - | - |
| BM014F02 | 104*140 | - | - | - | - | - |
| BM015F02 | 106*140 | - | - | - | - | - |
| BM016F02 | 108*140 | - | - | - | - | - |

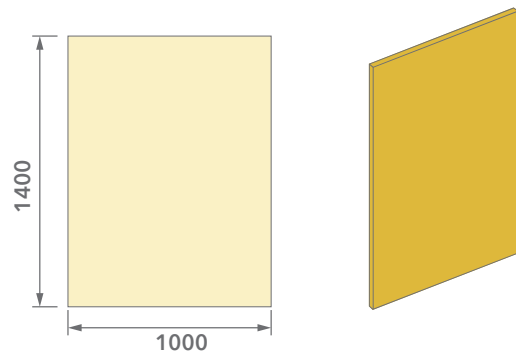

BM MODULAR WALLS-MDF

BM001F03

| Code | Stand Size | Panels | Panel Size | Max | Packing | Total |
|----------|------------|--------|------------|-----|---------|-------|
| | Cm | Qty | Cm | Kg | Cm | Kg |
| BM001F03 | 40*100 | - | - | - | - | - |
| BM002F03 | 44*100 | - | - | - | - | - |
| BM003F03 | 46*100 | - | - | - | - | - |
| BM004F03 | 48*100 | - | - | - | - | - |

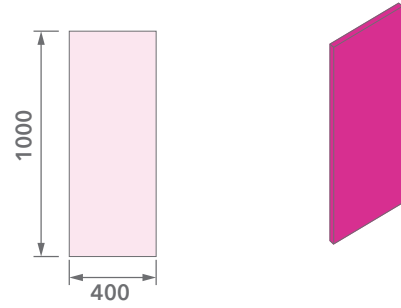

BM005F03

| Code | Stand Size | Panels | Panel Size | Max | Packing | Total |
|----------|------------|--------|------------|-----|---------|-------|
| | Cm | Qty | Cm | Kg | Cm | Kg |
| BM005F03 | 60*100 | - | - | - | - | - |
| BM006F03 | 64*100 | - | - | - | - | - |
| BM007F03 | 66*100 | - | - | - | - | - |
| BM008F03 | 68*100 | - | - | - | - | - |

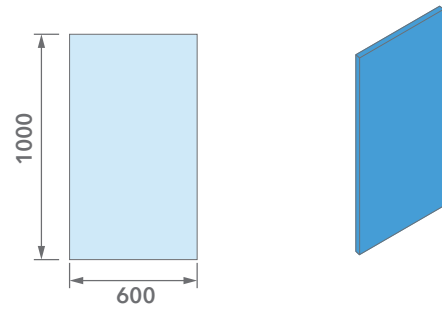

BM009F03

| Code | Stand Size | Panels | Panel Size | Max | Packing | Total |
|----------|------------|--------|------------|-----|---------|-------|
| | Cm | Qty | Cm | Kg | Cm | Kg |
| BM009F03 | 80*100 | - | - | - | - | - |
| BM010F03 | 84*100 | - | - | - | - | - |
| BM011F03 | 86*100 | - | - | - | - | - |
| BM012F03 | 88*100 | - | - | - | - | - |

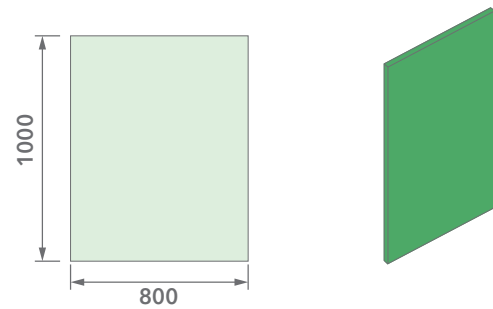

BM013F03

| Code | Stand Size | Panels | Panel Size | Max | Packing | Total |
|----------|------------|--------|------------|-----|---------|-------|
| | Cm | Qty | Cm | Kg | Cm | Kg |
| BM013F03 | 100*100 | - | - | - | - | - |
| BM014F03 | 104*100 | - | - | - | - | - |
| BM015F03 | 106*100 | - | - | - | - | - |
| BM016F03 | 108*100 | - | - | - | - | - |

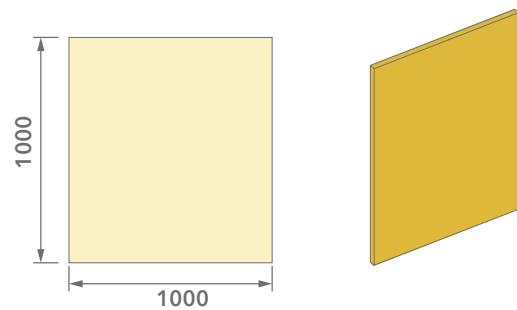

BM001G01

| Code | Stand Size | Panels | Panel Size | Max | Packing | Total |
|----------|------------|--------|------------|-----|---------|-------|
| | Cm | Qty | Cm | Kg | Cm | Kg |
| BM001G01 | 40*240 | - | - | - | - | - |
| BM002G01 | 44*240 | - | - | - | - | - |
| BM003G01 | 46*240 | - | - | - | - | - |
| BM004G01 | 48*240 | - | - | - | - | - |

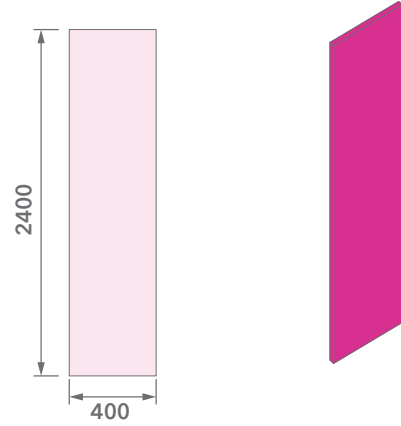

BM005G01

| Code | Stand Size | Panels | Panel Size | Max | Packing | Total |
|----------|------------|--------|------------|-----|---------|-------|
| | Cm | Qty | Cm | Kg | Cm | Kg |
| BM005G01 | 60*240 | - | - | - | - | - |
| BM006G01 | 64*240 | - | - | - | - | - |
| BM007G01 | 66*240 | - | - | - | - | - |
| BM008G01 | 68*240 | - | - | - | - | - |

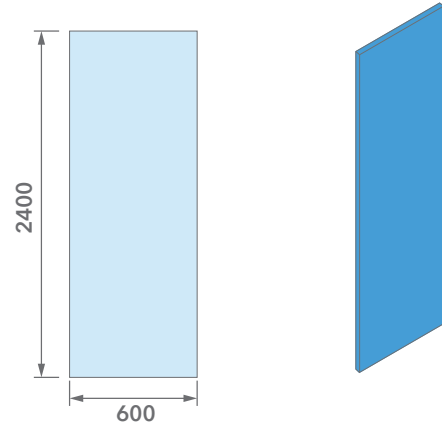

BM009G01

| Code | Stand Size | Panels | Panel Size | Max | Packing | Total |
|----------|------------|--------|------------|-----|---------|-------|
| | Cm | Qty | Cm | Kg | Cm | Kg |
| BM009G01 | 80*240 | - | - | - | - | - |
| BM010G01 | 84*240 | - | - | - | - | - |
| BM011G01 | 86*240 | - | - | - | - | - |
| BM012G01 | 88*240 | - | - | - | - | - |

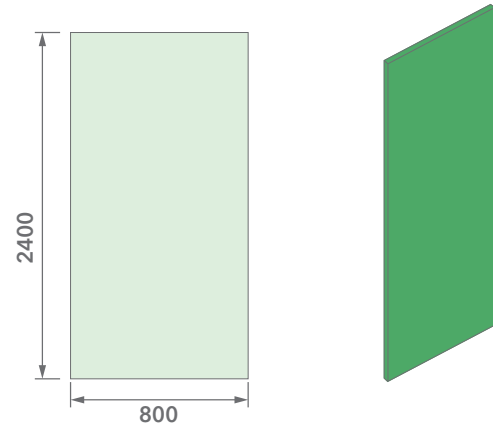

BM013G01

| Code | Stand Size | Panels | Panel Size | Max | Packing | Total |
|----------|------------|--------|------------|-----|---------|-------|
| | Cm | Qty | Cm | Kg | Cm | Kg |
| BM013G01 | 100*240 | - | - | - | - | - |
| BM014G01 | 104*240 | - | - | - | - | - |
| BM015G01 | 106*240 | - | - | - | - | - |
| BM016G01 | 108*240 | - | - | - | - | - |

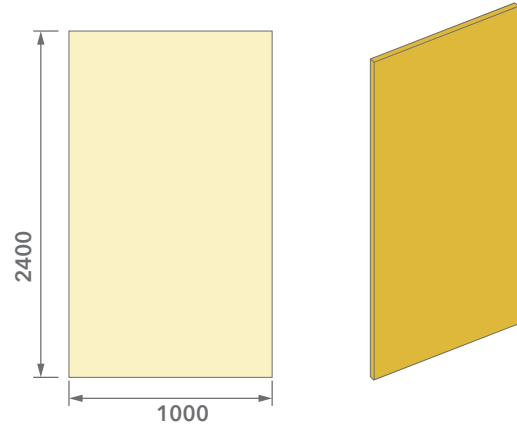

BM001G02

| Code | Stand Size | Panels | Panel Size | Max | Packing | Total |
|----------|------------|--------|------------|-----|---------|-------|
| | Cm | Qty | Cm | Kg | Cm | Kg |
| BM001G02 | 40*140 | - | - | - | - | - |
| BM002G02 | 44*140 | - | - | - | - | - |
| BM003G02 | 46*140 | - | - | - | - | - |
| BM004G02 | 48*140 | - | - | - | - | - |

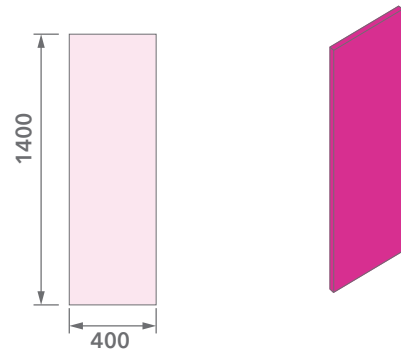

BM005G02

| Code | Stand Size | Panels | Panel Size | Max | Packing | Total |
|----------|------------|--------|------------|-----|---------|-------|
| | Cm | Qty | Cm | Kg | Cm | Kg |
| BM005G02 | 60*140 | - | - | - | - | - |
| BM006G02 | 64*140 | - | - | - | - | - |
| BM007G02 | 66*140 | - | - | - | - | - |
| BM008G02 | 68*140 | - | - | - | - | - |

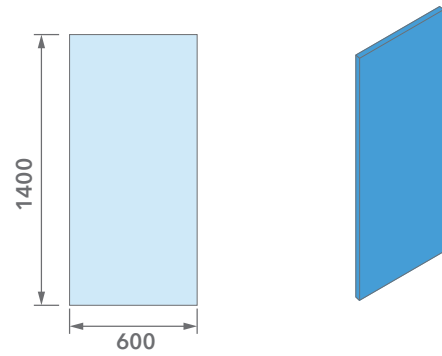

BM009G02

| Code | Stand Size | Panels | Panel Size | Max | Packing | Total |
|----------|------------|--------|------------|-----|---------|-------|
| | Cm | Qty | Cm | Kg | Cm | Kg |
| BM009G02 | 80*140 | - | - | - | - | - |
| BM010G02 | 84*140 | - | - | - | - | - |
| BM011G02 | 86*140 | - | - | - | - | - |
| BM012G02 | 88*140 | - | - | - | - | - |

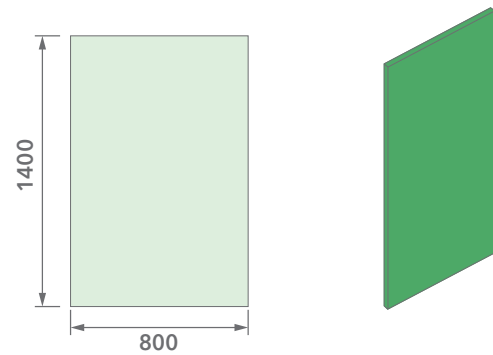

BM013G02

| Code | Stand Size | Panels | Panel Size | Max | Packing | Total |
|----------|------------|--------|------------|-----|---------|-------|
| | Cm | Qty | Cm | Kg | Cm | Kg |
| BM013G02 | 100*140 | - | - | - | - | - |
| BM014G02 | 104*140 | - | - | - | - | - |
| BM015G02 | 106*140 | - | - | - | - | - |
| BM016G02 | 108*140 | - | - | - | - | - |

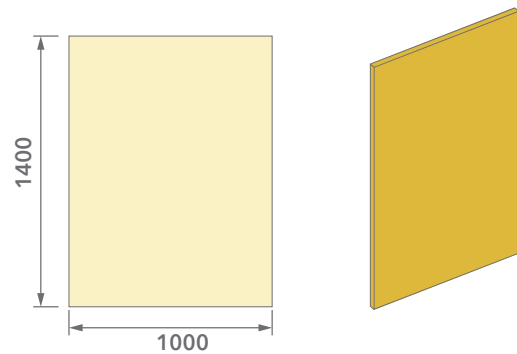

BM001G03

| Code | Stand Size | Panels | Panel Size | Max | Packing | Total |
|----------|------------|--------|------------|-----|---------|-------|
| | Cm | Qty | Cm | Kg | Cm | Kg |
| BM001G03 | 40*100 | - | - | - | - | - |
| BM002G03 | 44*100 | - | - | - | - | - |
| BM003G03 | 46*100 | - | - | - | - | - |
| BM004G03 | 48*100 | - | - | - | - | - |

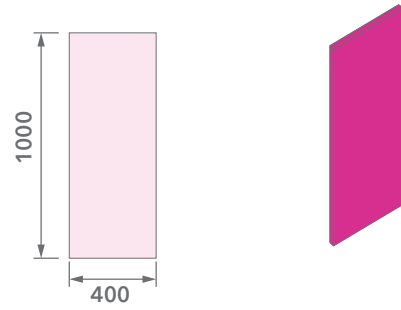

BM005G03

| Code | Stand Size | Panels | Panel Size | Max | Packing | Total |
|----------|------------|--------|------------|-----|---------|-------|
| | Cm | Qty | Cm | Kg | Cm | Kg |
| BM005G03 | 60*100 | - | - | - | - | - |
| BM006G03 | 64*100 | - | - | - | - | - |
| BM007G03 | 66*100 | - | - | - | - | - |
| BM008G03 | 68*100 | - | - | - | - | - |

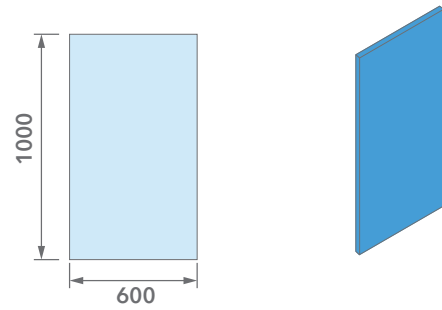

BM009G03

| Code | Stand Size | Panels | Panel Size | Max | Packing | Total |
|----------|------------|--------|------------|-----|---------|-------|
| | Cm | Qty | Cm | Kg | Cm | Kg |
| BM009G03 | 80*100 | - | - | - | - | - |
| BM010G03 | 84*100 | - | - | - | - | - |
| BM011G03 | 86*100 | - | - | - | - | - |
| BM012G03 | 88*100 | - | - | - | - | - |

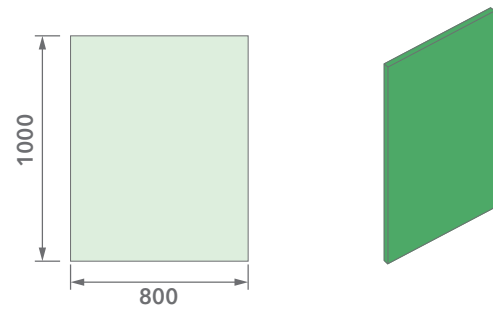

BM013G03

| Code | Stand Size | Panels | Panel Size | Max | Packing | Total |
|----------|------------|--------|------------|-----|---------|-------|
| | Cm | Qty | Cm | Kg | Cm | Kg |
| BM013G03 | 100*100 | - | - | - | - | - |
| BM014G03 | 104*100 | - | - | - | - | - |
| BM015G03 | 106*100 | - | - | - | - | - |
| BM016G03 | 108*100 | - | - | - | - | - |

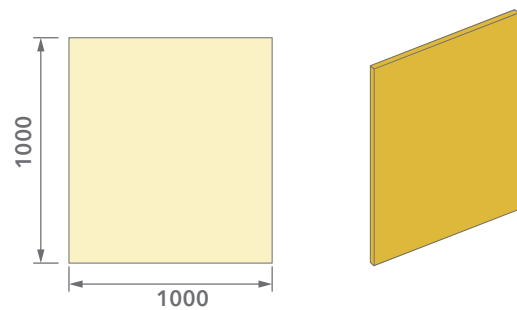

BM MODULAR WALLS MDF LACQUER

BM001I01

| Code | Stand Size | Panels | Panel Size | Max | Packing | Total |
|----------|------------|--------|------------|-----|---------|-------|
| | Cm | Qty | Cm | Kg | Cm | Kg |
| BM001I01 | 40*240 | - | - | - | - | - |
| BM002I01 | 44*240 | - | - | - | - | - |
| BM003I01 | 46*240 | - | - | - | - | - |
| BM004I01 | 48*240 | - | - | - | - | - |

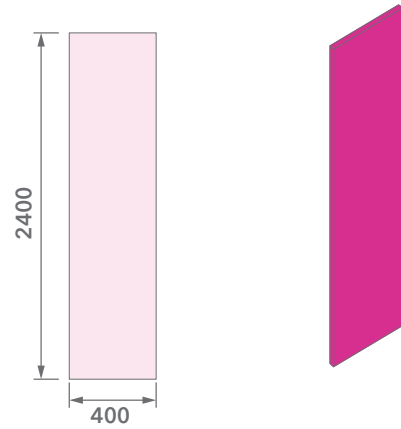

BM005I01

| Code | Stand Size | Panels | Panel Size | Max | Packing | Total |
|----------|------------|--------|------------|-----|---------|-------|
| | Cm | Qty | Cm | Kg | Cm | Kg |
| BM005I01 | 60*240 | - | - | - | - | - |
| BM006I01 | 64*240 | - | - | - | - | - |
| BM007I01 | 66*240 | - | - | - | - | - |
| BM008I01 | 68*240 | - | - | - | - | - |

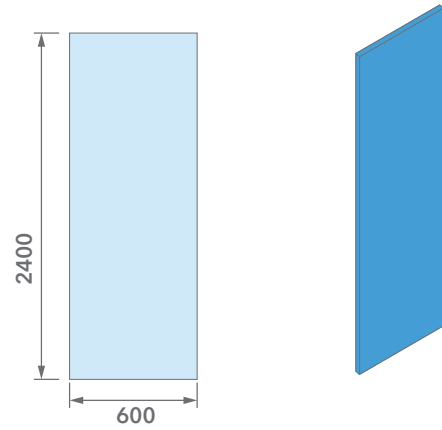

BM009I01

| Code | Stand Size | Panels | Panel Size | Max | Packing | Total |
|----------|------------|--------|------------|-----|---------|-------|
| | Cm | Qty | Cm | Kg | Cm | Kg |
| BM009I01 | 80*240 | - | - | - | - | - |
| BM010I01 | 84*240 | - | - | - | - | - |
| BM011I01 | 86*240 | - | - | - | - | - |
| BM012I01 | 88*240 | - | - | - | - | - |

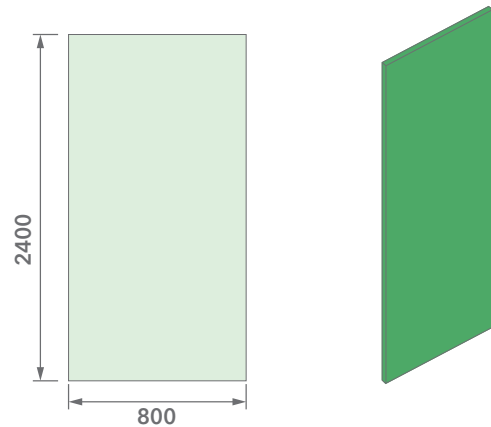

BM013I01

| Code | Stand Size | Panels | Panel Size | Max | Packing | Total |
|----------|------------|--------|------------|-----|---------|-------|
| | Cm | Qty | Cm | Kg | Cm | Kg |
| BM013I01 | 100*240 | - | - | - | - | - |
| BM014I01 | 104*240 | - | - | - | - | - |
| BM015I01 | 106*240 | - | - | - | - | - |
| BM016I01 | 108*240 | - | - | - | - | - |

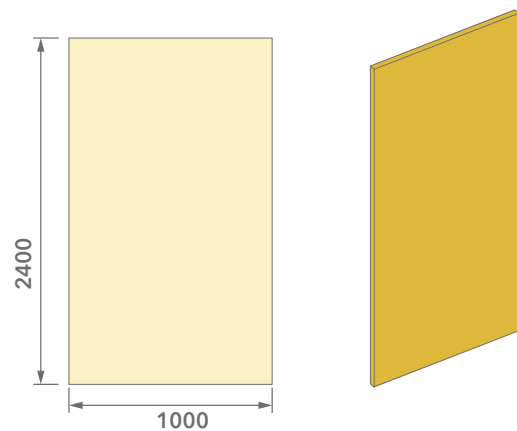

BM MODULAR WALLS MDF LACQUER

BM001I02

| Code | Stand Size | Panels | Panel Size | Max | Packing | Total |
|----------|------------|--------|------------|-----|---------|-------|
| | Cm | Qty | Cm | Kg | Cm | Kg |
| BM001I02 | 40*140 | - | - | - | - | - |
| BM002I02 | 44*140 | - | - | - | - | - |
| BM003I02 | 46*140 | - | - | - | - | - |
| BM004I02 | 48*140 | - | - | - | - | - |

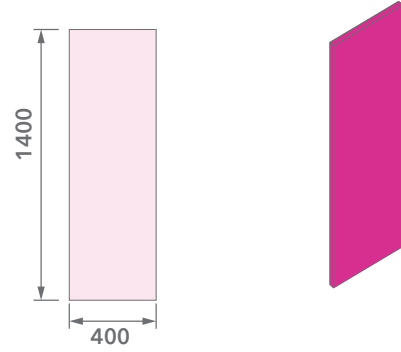

BM005I02

| Code | Stand Size | Panels | Panel Size | Max | Packing | Total |
|----------|------------|--------|------------|-----|---------|-------|
| | Cm | Qty | Cm | Kg | Cm | Kg |
| BM005I02 | 60*140 | - | - | - | - | - |
| BM006I02 | 64*140 | - | - | - | - | - |
| BM007I02 | 66*140 | - | - | - | - | - |
| BM008I02 | 68*140 | - | - | - | - | - |

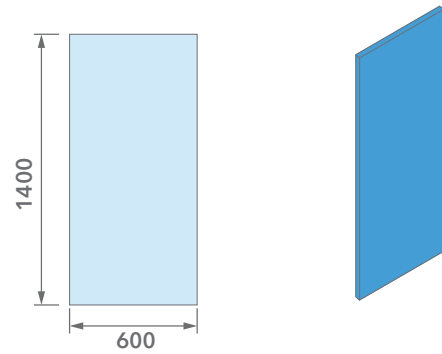

BM009I02

| Code | Stand Size | Panels | Panel Size | Max | Packing | Total |
|----------|------------|--------|------------|-----|---------|-------|
| | Cm | Qty | Cm | Kg | Cm | Kg |
| BM009I02 | 80*140 | - | - | - | - | - |
| BM010I02 | 84*140 | - | - | - | - | - |
| BM011I02 | 86*140 | - | - | - | - | - |
| BM012I02 | 88*140 | - | - | - | - | - |

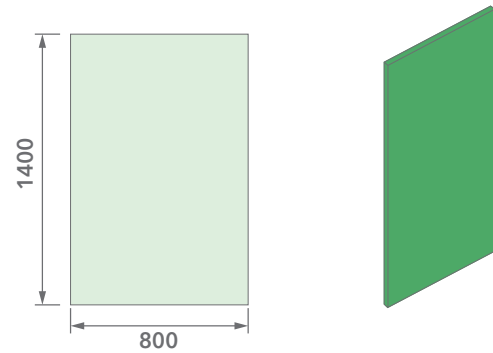

BM013I02

| Code | Stand Size | Panels | Panel Size | Max | Packing | Total |
|----------|------------|--------|------------|-----|---------|-------|
| | Cm | Qty | Cm | Kg | Cm | Kg |
| BM013I02 | 100*140 | - | - | - | - | - |
| BM014I02 | 104*140 | - | - | - | - | - |
| BM015I02 | 106*140 | - | - | - | - | - |
| BM016I02 | 108*140 | - | - | - | - | - |

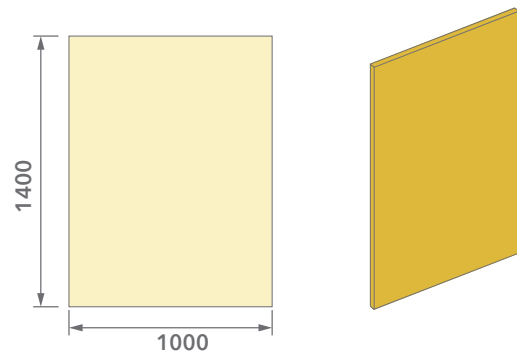

BM MODULAR WALLS MDF LACQUER

BM001I03

| Code | Stand Size | Panels | Panel Size | Max | Packing | Total |
|----------|------------|--------|------------|-----|---------|-------|
| | Cm | Qty | Cm | Kg | Cm | Kg |
| BM001I03 | 40*100 | - | - | - | - | - |
| BM002I03 | 44*100 | - | - | - | - | - |
| BM003I03 | 46*100 | - | - | - | - | - |
| BM004I03 | 48*100 | - | - | - | - | - |

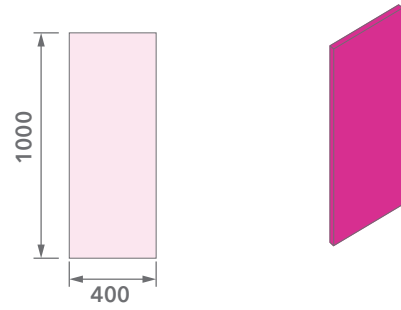

BM005I03

| Code | Stand Size | Panels | Panel Size | Max | Packing | Total |
|----------|------------|--------|------------|-----|---------|-------|
| | Cm | Qty | Cm | Kg | Cm | Kg |
| BM005I03 | 60*100 | - | - | - | - | - |
| BM006I03 | 64*100 | - | - | - | - | - |
| BM007I03 | 66*100 | - | - | - | - | - |
| BM008I03 | 68*100 | - | - | - | - | - |

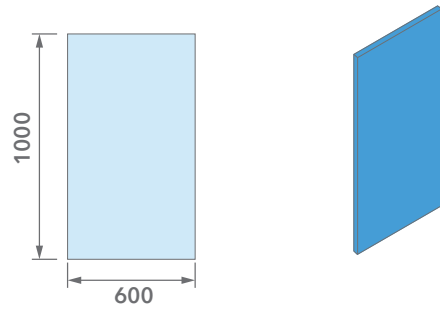

BM009I03

| Code | Stand Size | Panels | Panel Size | Max | Packing | Total |
|----------|------------|--------|------------|-----|---------|-------|
| | Cm | Qty | Cm | Kg | Cm | Kg |
| BM009I03 | 80*100 | - | - | - | - | - |
| BM010I03 | 84*100 | - | - | - | - | - |
| BM011I03 | 86*100 | - | - | - | - | - |
| BM012I03 | 88*100 | - | - | - | - | - |

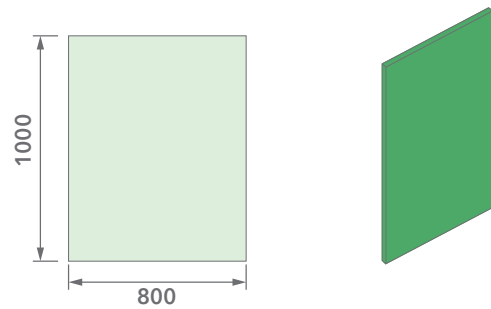

BM013I03

| Code | Stand Size | Panels | Panel Size | Max | Packing | Total |
|----------|------------|--------|------------|-----|---------|-------|
| | Cm | Qty | Cm | Kg | Cm | Kg |
| BM013I03 | 100*100 | - | - | - | - | - |
| BM014I03 | 104*100 | - | - | - | - | - |
| BM015I03 | 106*100 | - | - | - | - | - |
| BM016I03 | 108*100 | - | - | - | - | - |

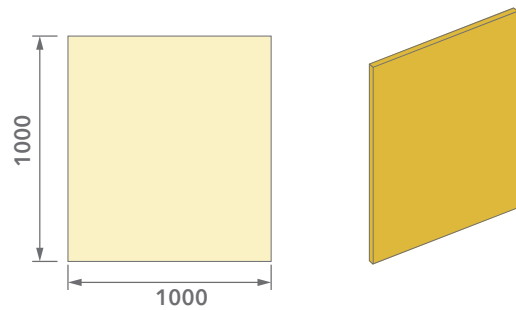

BW TECHNICAL WALL

BW017F01

| Code | Stand Size | Panels | Panel Size | Max | Packing | Total |
|----------|------------|--------|------------|-----|---------|-------|
| | Cm | Qty | Cm | Kg | Cm | Kg |
| BW017F01 | 40*240 | - | - | - | - | - |
| BW018F01 | 44*240 | - | - | - | - | - |
| BW019F01 | 46*240 | - | - | - | - | - |
| BW020F01 | 48*240 | - | - | - | - | - |

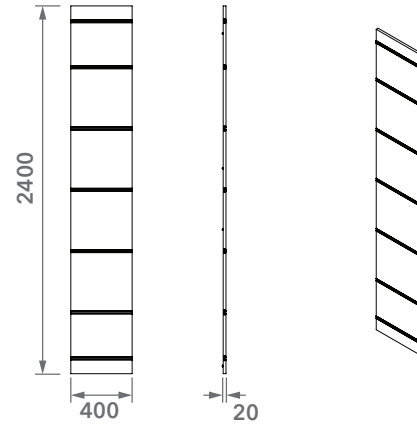

BW021F01

| Code | Stand Size | Panels | Panel Size | Max | Packing | Total |
|----------|------------|--------|------------|-----|---------|-------|
| | Cm | Qty | Cm | Kg | Cm | Kg |
| BW021F01 | 60*240 | - | - | - | - | - |
| BW022F01 | 64*240 | - | - | - | - | - |
| BW023F01 | 66*240 | - | - | - | - | - |
| BW024F01 | 68*240 | - | - | - | - | - |

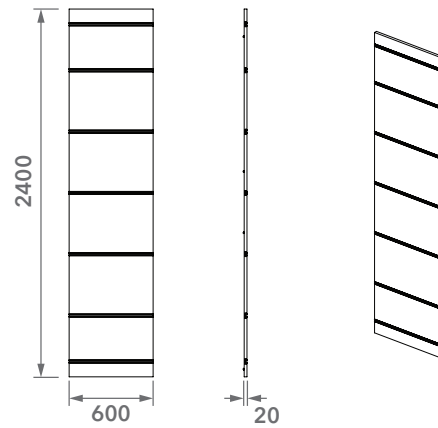

BW025F01

| Code | Stand Size | Panels | Panel Size | Max | Packing | Total |
|----------|------------|--------|------------|-----|---------|-------|
| | Cm | Qty | Cm | Kg | Cm | Kg |
| BW025F01 | 80*240 | - | - | - | - | - |
| BW026F01 | 84*240 | - | - | - | - | - |
| BW027F01 | 86*240 | - | - | - | - | - |
| BW028F01 | 88*240 | - | - | - | - | - |

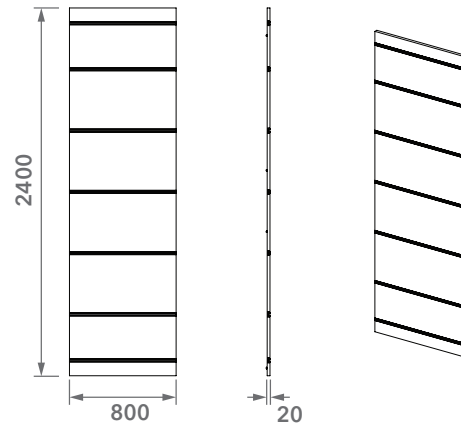

BW029F01

| Code | Stand Size | Panels | Panel Size | Max | Packing | Total |
|----------|------------|--------|------------|-----|---------|-------|
| | Cm | Qty | Cm | Kg | Cm | Kg |
| BW029F01 | 100*240 | - | - | - | - | - |
| BW030F01 | 104*240 | - | - | - | - | - |
| BW031F01 | 106*240 | - | - | - | - | - |
| BW032F01 | 108*240 | - | - | - | - | - |

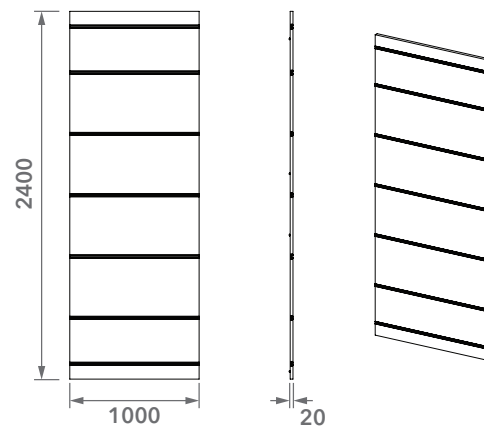

BW TECHNICAL WALL

BW017F02

| Code | Stand Size | Panels | Panel Size | Max | Packing | Total |
|----------|------------|--------|------------|-----|---------|-------|
| | Cm | Qty | Cm | Kg | Cm | Kg |
| BW017F02 | 40*140 | - | - | - | - | - |
| BW018F02 | 44*140 | - | - | - | - | - |
| BW019F02 | 46*140 | - | - | - | - | - |
| BW020F02 | 48*140 | - | - | - | - | - |

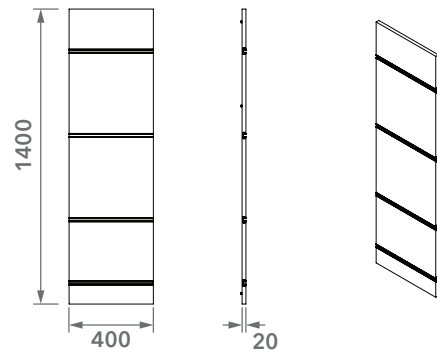

BW021F02

| Code | Stand Size | Panels | Panel Size | Max | Packing | Total |
|----------|------------|--------|------------|-----|---------|-------|
| | Cm | Qty | Cm | Kg | Cm | Kg |
| BW021F02 | 60*140 | - | - | - | - | - |
| BW022F02 | 64*140 | - | - | - | - | - |
| BW023F02 | 66*140 | - | - | - | - | - |
| BW024F02 | 68*140 | - | - | - | - | - |

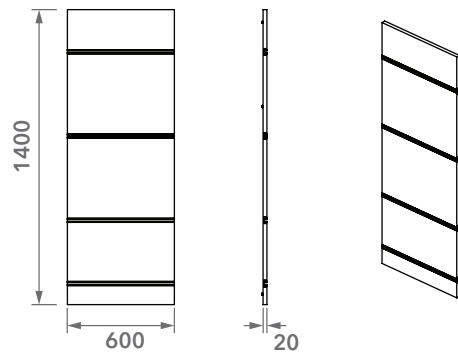

BW025F02

| Code | Stand Size | Panels | Panel Size | Max | Packing | Total |
|----------|------------|--------|------------|-----|---------|-------|
| | Cm | Qty | Cm | Kg | Cm | Kg |
| BW025F02 | 80*140 | - | - | - | - | - |
| BW026F02 | 84*140 | - | - | - | - | - |
| BW027F02 | 86*140 | - | - | - | - | - |
| BW028F02 | 88*140 | - | - | - | - | - |

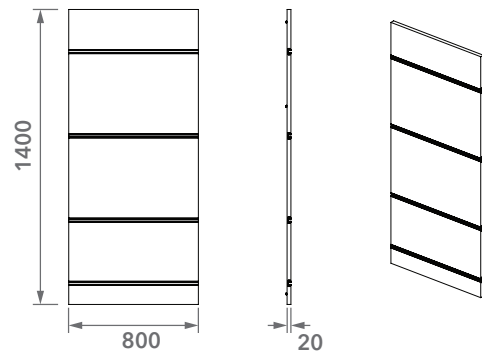

BW029F02

| Code | Stand Size | Panels | Panel Size | Max | Packing | Total |
|----------|------------|--------|------------|-----|---------|-------|
| | Cm | Qty | Cm | Kg | Cm | Kg |
| BW029F02 | 100*140 | - | - | - | - | - |
| BW030F02 | 104*240 | - | - | - | - | - |
| BW031F02 | 106*240 | - | - | - | - | - |
| BW032F02 | 108*140 | - | - | - | - | - |

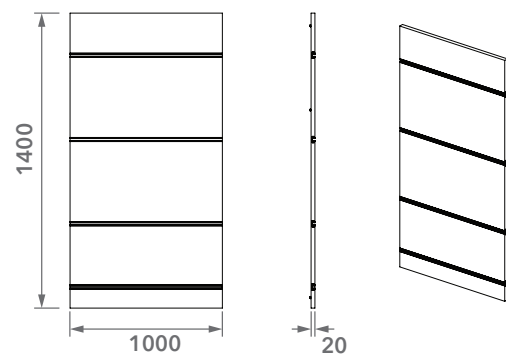

BW TECHNICAL WALL

BW017F03

| Code | Stand Size | Panels | Panel Size | Max | Packing | Total |
|----------|------------|--------|------------|-----|---------|-------|
| | Cm | Qty | Cm | Kg | Cm | Kg |
| BW017F03 | 40*100 | - | - | - | - | - |
| BW018F03 | 44*100 | - | - | - | - | - |
| BW019F03 | 46*100 | - | - | - | - | - |
| BW020F03 | 48*100 | - | - | - | - | - |

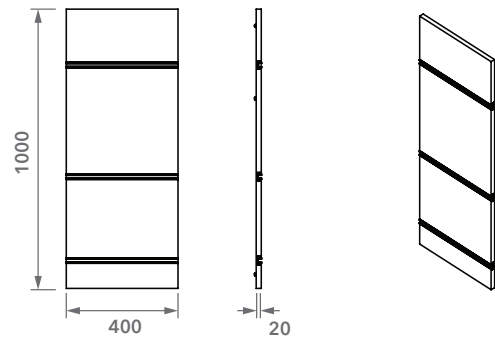

BW021F03

| Code | Stand Size | Panels | Panel Size | Max | Packing | Total |
|----------|------------|--------|------------|-----|---------|-------|
| | Cm | Qty | Cm | Kg | Cm | Kg |
| BW021F03 | 60*100 | - | - | - | - | - |
| BW022F03 | 64*100 | - | - | - | - | - |
| BW023F03 | 66*100 | - | - | - | - | - |
| BW024F03 | 68*100 | - | - | - | - | - |

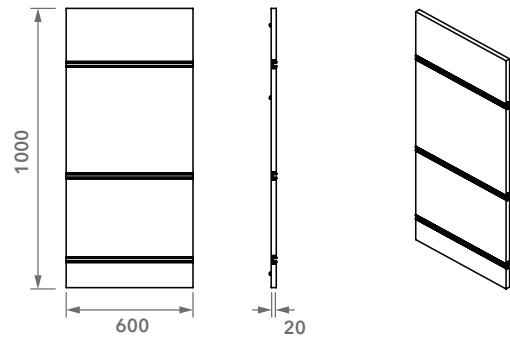

BW025F03

| Code | Stand Size | Panels | Panel Size | Max | Packing | Total |
|----------|------------|--------|------------|-----|---------|-------|
| | Cm | Qty | Cm | Kg | Cm | Kg |
| BW025F03 | 80*100 | - | - | - | - | - |
| BW026F03 | 84*100 | - | - | - | - | - |
| BW027F03 | 86*100 | - | - | - | - | - |
| BW028F03 | 88*100 | - | - | - | - | - |

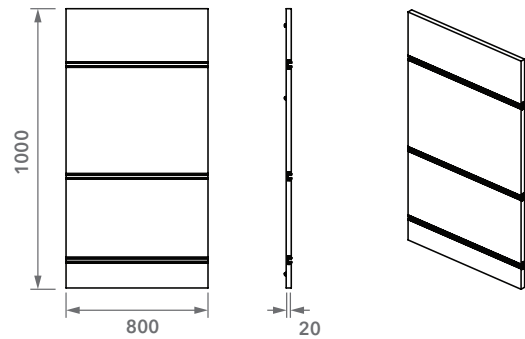

BW029F03

| Code | Stand Size | Panels | Panel Size | Max | Packing | Total |
|----------|------------|--------|------------|-----|---------|-------|
| | Cm | Qty | Cm | Kg | Cm | Kg |
| BW029F03 | 100*100 | - | - | - | - | - |
| BW030F03 | 104*100 | - | - | - | - | - |
| BW031F03 | 106*100 | - | - | - | - | - |
| BW032F03 | 108*100 | - | - | - | - | - |

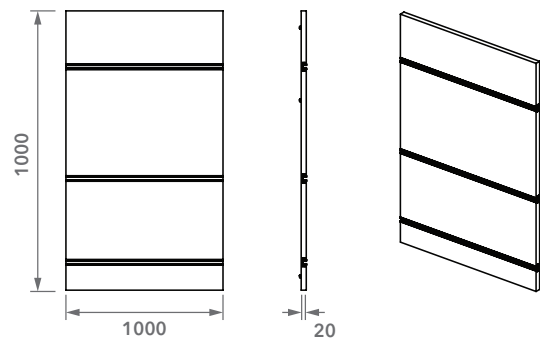

BW TECHNICAL WALL

BW033F01

| Code | Stand Size | Panels | Panel Size | Max | Packing | Total |
|----------|------------|--------|------------|-----|---------|-------|
| | Cm | Qty | Cm | Kg | Cm | Kg |
| BW033F01 | 40*240 | - | - | - | - | - |
| BW034F01 | 44*240 | - | - | - | - | - |
| BW035F01 | 46*240 | - | - | - | - | - |
| BW036F01 | 48*240 | - | - | - | - | - |

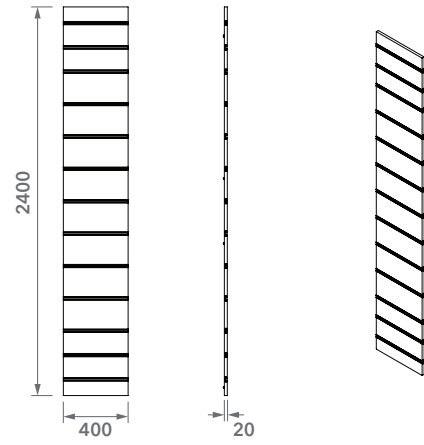

BW037F01

| Code | Stand Size | Panels | Panel Size | Max | Packing | Total |
|----------|------------|--------|------------|-----|---------|-------|
| | Cm | Qty | Cm | Kg | Cm | Kg |
| BW037F01 | 60*240 | - | - | - | - | - |
| BW038F01 | 64*240 | - | - | - | - | - |
| BW039F01 | 66*240 | - | - | - | - | - |
| BW040F01 | 68*240 | - | - | - | - | - |

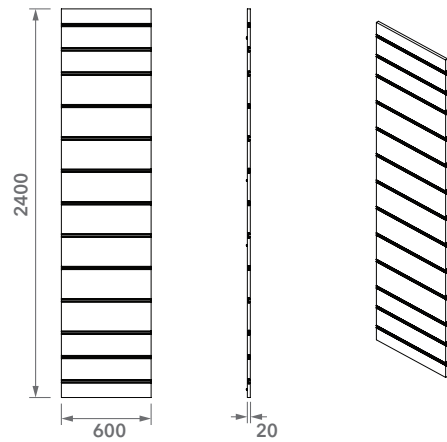

BW041F01

| Code | Stand Size | Panels | Panel Size | Max | Packing | Total |
|----------|------------|--------|------------|-----|---------|-------|
| | Cm | Qty | Cm | Kg | Cm | Kg |
| BW041F01 | 80*240 | - | - | - | - | - |
| BW042F01 | 84*240 | - | - | - | - | - |
| BW043F01 | 86*240 | - | - | - | - | - |
| BW044F01 | 88*240 | - | - | - | - | - |

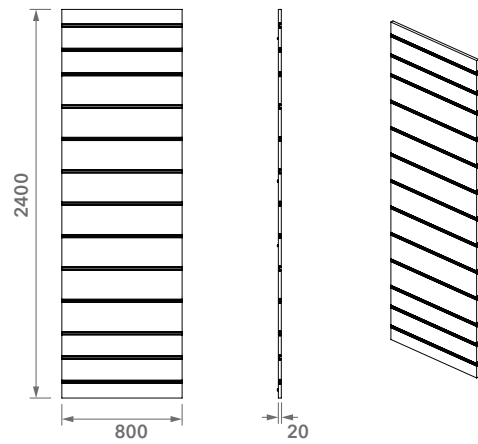

BW045F01

| Code | Stand Size | Panels | Panel Size | Max | Packing | Total |
|----------|------------|--------|------------|-----|---------|-------|
| | Cm | Qty | Cm | Kg | Cm | Kg |
| BW045F01 | 100*240 | - | - | - | - | - |
| BW046F01 | 104*240 | - | - | - | - | - |
| BW047F01 | 106*240 | - | - | - | - | - |
| BW048F01 | 108*240 | - | - | - | - | - |

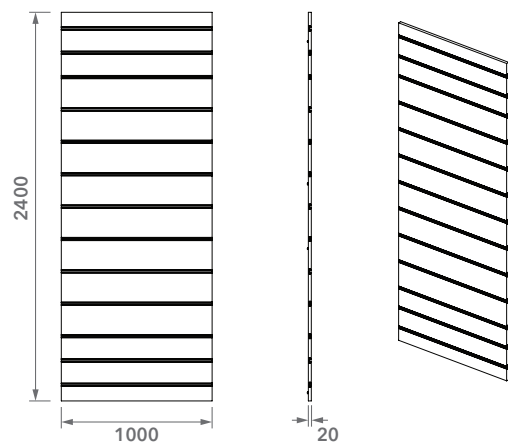

BW TECHNICAL WALL

BW033F02

| Code | Stand Size | Panels | Panel Size | Max | Packing | Total |
|----------|------------|--------|------------|-----|---------|-------|
| | Cm | Qty | Cm | Kg | Cm | Kg |
| BW033F02 | 40*140 | - | - | - | - | - |
| BW034F02 | 44*140 | - | - | - | - | - |
| BW035F02 | 46*140 | - | - | - | - | - |
| BW036F02 | 48*140 | - | - | - | - | - |

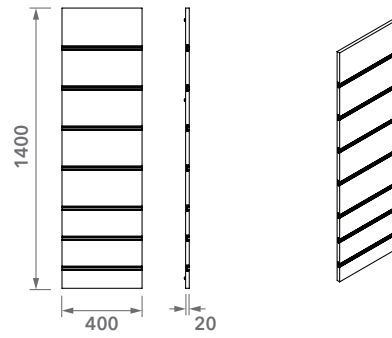

BW037F02

| Code | Stand Size | Panels | Panel Size | Max | Packing | Total |
|----------|------------|--------|------------|-----|---------|-------|
| | Cm | Qty | Cm | Kg | Cm | Kg |
| BW037F02 | 60*140 | - | - | - | - | - |
| BW038F02 | 64*140 | - | - | - | - | - |
| BW039F02 | 66*140 | - | - | - | - | - |
| BW040F02 | 68*140 | - | - | - | - | - |

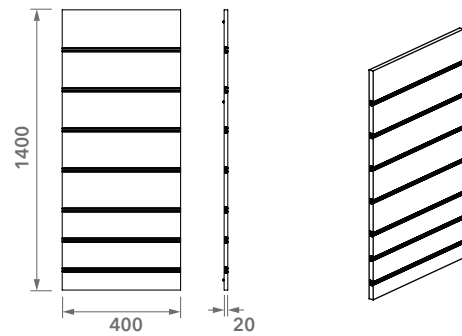

BW041F02

| Code | Stand Size | Panels | Panel Size | Max | Packing | Total |
|----------|------------|--------|------------|-----|---------|-------|
| | Cm | Qty | Cm | Kg | Cm | Kg |
| BW041F02 | 80*140 | - | - | - | - | - |
| BW042F02 | 84*140 | - | - | - | - | - |
| BW043F02 | 86*140 | - | - | - | - | - |
| BW044F02 | 88*140 | - | - | - | - | - |

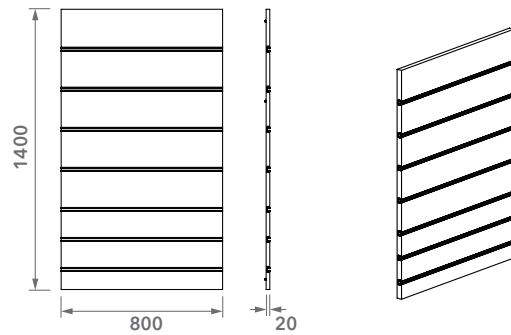

BW045F02

| Code | Stand Size | Panels | Panel Size | Max | Packing | Total |
|----------|------------|--------|------------|-----|---------|-------|
| | Cm | Qty | Cm | Kg | Cm | Kg |
| BW045F02 | 100*140 | - | - | - | - | - |
| BW046F02 | 104*240 | - | - | - | - | - |
| BW047F02 | 106*240 | - | - | - | - | - |
| BW048F02 | 108*140 | - | - | - | - | - |

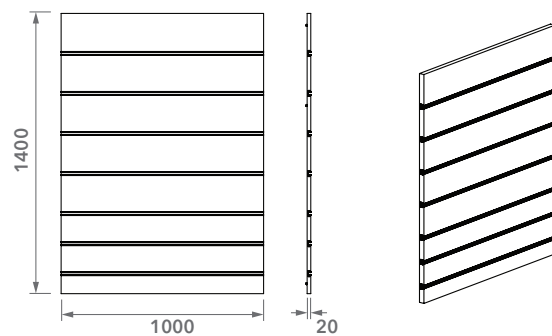

BW TECHNICAL WALL

BW033F03

| Code | Stand Size | Panels | Panel Size | Max | Packing | Total |
|----------|------------|--------|------------|-----|---------|-------|
| | Cm | Qty | Cm | Kg | Cm | Kg |
| BW033F03 | 40*100 | - | - | - | - | - |
| BW034F03 | 44*100 | - | - | - | - | - |
| BW035F03 | 46*100 | - | - | - | - | - |
| BW036F03 | 48*100 | - | - | - | - | - |

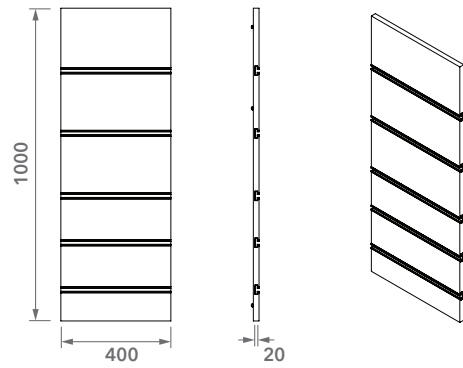

BW037F03

| Code | Stand Size | Panels | Panel Size | Max | Packing | Total |
|----------|------------|--------|------------|-----|---------|-------|
| | Cm | Qty | Cm | Kg | Cm | Kg |
| BW037F03 | 60*100 | - | - | - | - | - |
| BW038F03 | 64*100 | - | - | - | - | - |
| BW039F03 | 66*100 | - | - | - | - | - |
| BW040F03 | 68*100 | - | - | - | - | - |

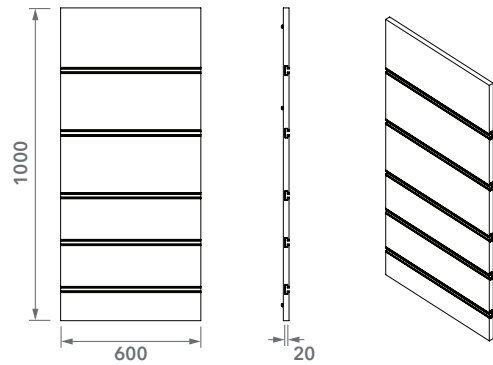

BW041F03

| Code | Stand Size | Panels | Panel Size | Max | Packing | Total |
|----------|------------|--------|------------|-----|---------|-------|
| | Cm | Qty | Cm | Kg | Cm | Kg |
| BW041F03 | 80*100 | - | - | - | - | - |
| BW042F03 | 84*100 | - | - | - | - | - |
| BW043F03 | 86*100 | - | - | - | - | - |
| BW044F03 | 88*100 | - | - | - | - | - |

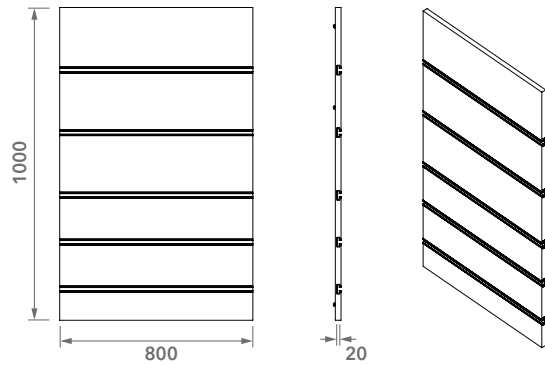

BW029F03

| Code | Stand Size | Panels | Panel Size | Max | Packing | Total |
|----------|------------|--------|------------|-----|---------|-------|
| | Cm | Qty | Cm | Kg | Cm | Kg |
| BW029F03 | 100*100 | - | - | - | - | - |
| BW030F03 | 104*100 | - | - | - | - | - |
| BW031F03 | 106*100 | - | - | - | - | - |
| BW032F03 | 108*100 | - | - | - | - | - |

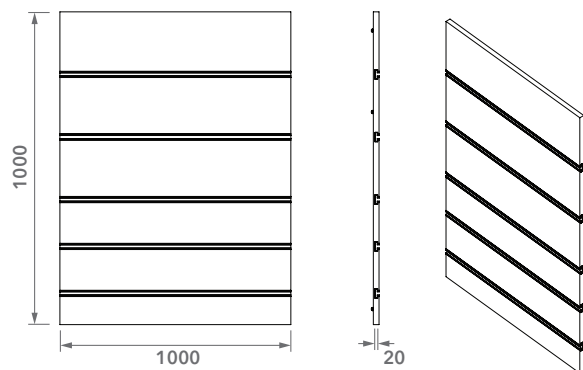

BM STRENGTHENING PART

BM001H

| Code | Stand Size | Panels | Panel Size | Max | Packing | Total |
|----------|------------|--------|------------|-----|---------|-------|
| | Cm | Qty | Cm | Kg | Cm | Kg |
| BM001H01 | 30.8*58*4 | - | - | - | - | - |

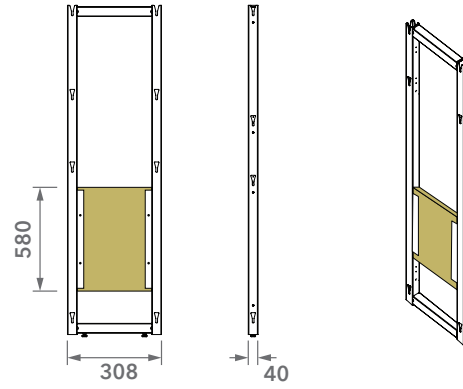

BM002H

| Code | Stand Size | Panels | Panel Size | Max | Packing | Total |
|----------|-------------|--------|------------|-----|---------|-------|
| | Cm | Qty | Cm | Kg | Cm | Kg |
| BM002H01 | 50.8*50.8*4 | - | - | - | - | - |

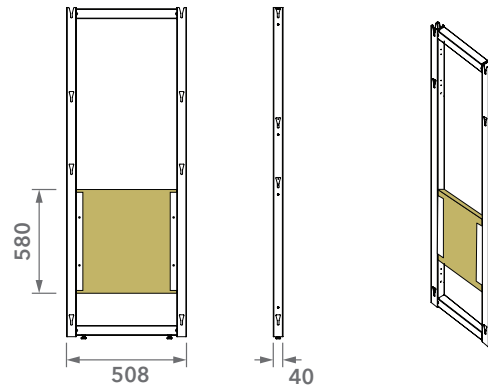

BM003H

| Code | Stand Size | Panels | Panel Size | Max | Packing | Total |
|----------|-------------|--------|------------|-----|---------|-------|
| | Cm | Qty | Cm | Kg | Cm | Kg |
| BM003H01 | 70.8*50.8*4 | - | - | - | - | - |

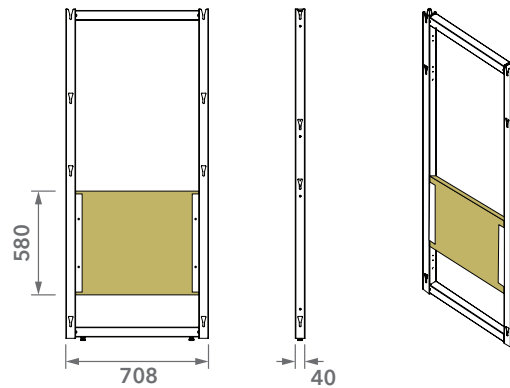

BM004H

| Code | Stand Size | Panels | Panel Size | Max | Packing | Total |
|----------|-------------|--------|------------|-----|---------|-------|
| | Cm | Qty | Cm | Kg | Cm | Kg |
| BM004H01 | 90.8*50.8*4 | - | - | - | - | - |

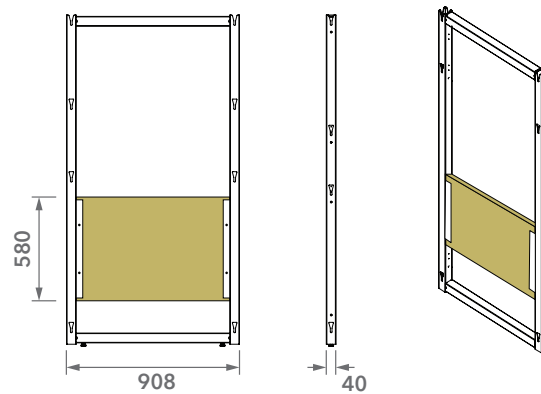

BM METAL FRAME ENDING PRF

BM201G01

VERTICAL ENDING PRF MDFLAM,CHPBRDLAM

| Code | Stand Size | Panels | Panel Size | Max | Packing | Total |
|----------|-------------|--------|------------|-----|---------|-------|
| | Cm | Qty | Cm | Kg | Cm | Kg |
| BM201G01 | 8.4*240*2.5 | - | - | - | - | - |
| BM201G02 | 8.4*140*2.5 | - | - | - | - | - |
| BM201G03 | 8.4*100*2.5 | - | - | - | - | - |

BM201I01

VERTICAL ENDING PRF LACQUER

| Code | Stand Size | Panels | Panel Size | Max | Packing | Total |
|----------|-------------|--------|------------|-----|---------|-------|
| | Cm | Qty | Cm | Kg | Cm | Kg |
| BM201I01 | 8.4*240*2.5 | - | - | - | - | - |
| BM201I02 | 8.4*140*2.5 | - | - | - | - | - |
| BM201I03 | 8.4*100*2.5 | - | - | - | - | - |

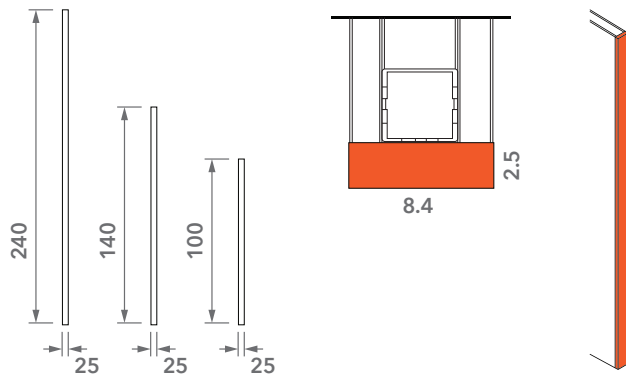

BM202G01

VERTICAL ENDING PRF MDFLAM, CHPBRDLAM

| Code | Stand Size | Panels | Panel Size | Max | Packing | Total |
|----------|-------------|--------|------------|-----|---------|-------|
| | Cm | Qty | Cm | Kg | Cm | Kg |
| BM202G01 | 8.4*240*1.8 | - | - | - | - | - |
| BM202G02 | 8.4*140*1.8 | - | - | - | - | - |
| BM202G03 | 8.4*240*1.8 | - | - | - | - | - |

BM202I01

VERTICAL ENDING PRF LACQUER

| Code | Stand Size | Panels | Panel Size | Max | Packing | Total |
|----------|-------------|--------|------------|-----|---------|-------|
| | Cm | Qty | Cm | Kg | Cm | Kg |
| BM202I01 | 8.4*240*2.5 | - | - | - | - | - |
| BM202I02 | 8.4*140*2.5 | - | - | - | - | - |
| BM202I03 | 8.4*100*2.5 | - | - | - | - | - |

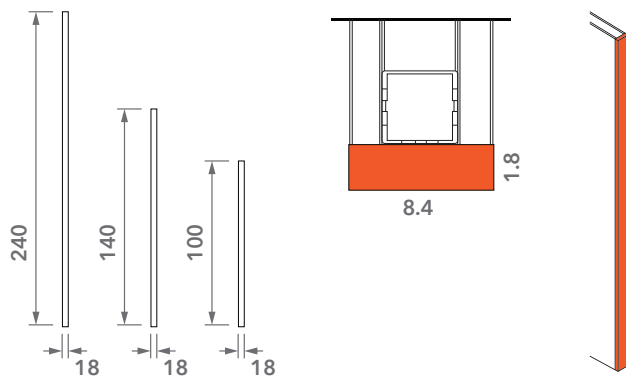

BM006L01

VERTICAL ENDING PRF

| Code | Stand Size | Panels | Panel Size | Max | Packing | Total |
|----------|-------------|--------|------------|-----|---------|-------|
| | Cm | Qty | Cm | Kg | Cm | Kg |
| BM006L01 | 8.1*240*1.5 | - | - | - | - | - |
| BM006L02 | 8.1*140*1.5 | - | - | - | - | - |
| BM006L03 | 8.1*100*1.5 | - | - | - | - | - |

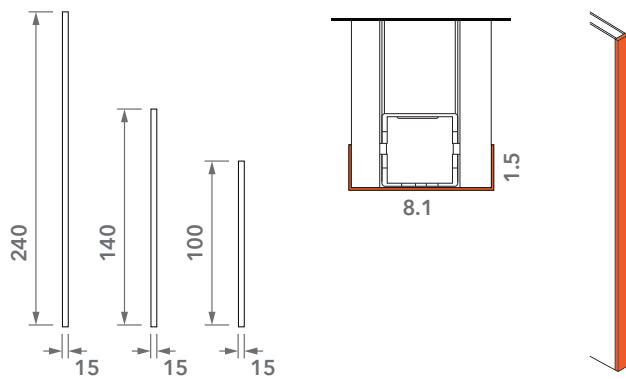

BM008LRL

VERTICAL ENDING PRF (SHEET METAL)

| Code | Stand Size | Panels | Panel Size | Max | Packing | Total |
|-----------|-------------|--------|------------|-----|---------|-------|
| | Cm | Qty | Cm | Kg | Cm | Kg |
| BM008L01R | 9.1*240*1.5 | - | - | - | - | - |
| BM008L02R | 9.1*140*1.5 | - | - | - | - | - |
| BM008L03R | 9.1*100*1.5 | - | - | - | - | - |
| BM008L01L | 9.1*240*1.5 | - | - | - | - | - |
| BM008L02L | 9.1*240*1.5 | - | - | - | - | - |
| BM008L03L | 9.1*240*1.5 | - | - | - | - | - |

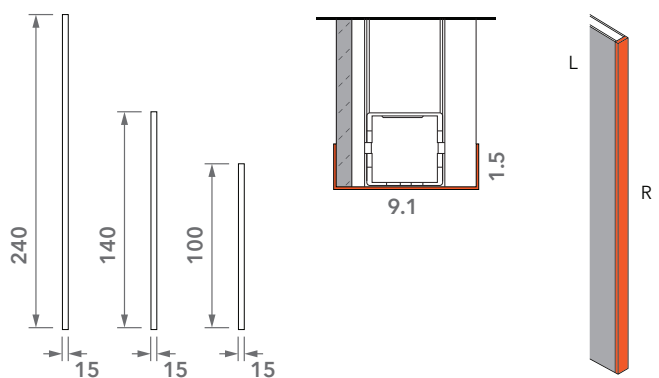

BM METAL FRAME ENDING PRF

BM204G01

VERTICAL ENDING PRF MDFLAM, CHPBRDLAM

| Code | Stand Size | Panels | Panel Size | Max | Packing | Total |
|----------|-------------|--------|------------|-----|---------|-------|
| | Cm | | | | | |
| BM204G01 | 6.2*240*1.8 | - | - | - | - | - |
| BM204G02 | 6.2*140*1.8 | - | - | - | - | - |
| BM204G03 | 6.2*100*1.8 | - | - | - | - | - |

BM204I01

VERTICAL ENDING PRF LACQUER

| Code | Stand Size | Panels | Panel Size | Max | Packing | Total |
|----------|-------------|--------|------------|-----|---------|-------|
| | Cm | | | | | |
| BM204I01 | 8.4*240*1.8 | - | - | - | - | - |
| BM204I02 | 8.4*140*1.8 | - | - | - | - | - |
| BM204I03 | 8.4*100*1.8 | - | - | - | - | - |

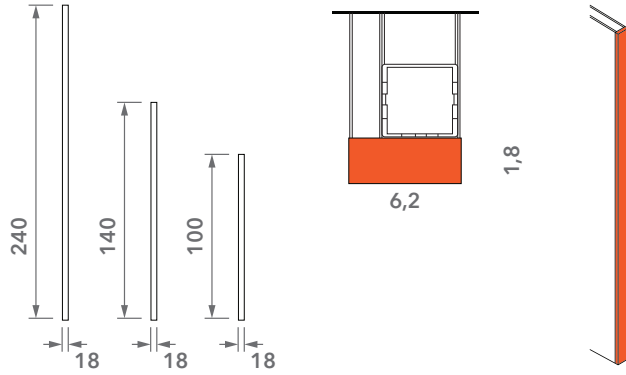

BM203G01

VERTICAL ENDING PRF MDFLAM, CHPBRDLAM

| Code | Stand Size | Panels | Panel Size | Max | Packing | Total |
|----------|-------------|--------|------------|-----|---------|-------|
| | Cm | | | | | |
| BM203G01 | 6.2*240*2.5 | - | - | - | - | - |
| BM203G02 | 6.2*140*2.5 | - | - | - | - | - |
| BM203G03 | 6.2*100*2.5 | - | - | - | - | - |

BM203I01

VERTICAL ENDING PRF LACQUER

| Code | Stand Size | Panels | Panel Size | Max | Packing | Total |
|----------|-------------|--------|------------|-----|---------|-------|
| | Cm | | | | | |
| BM203I01 | 8.4*240*2.5 | - | - | - | - | - |
| BM203I02 | 8.4*140*2.5 | - | - | - | - | - |
| BM203I03 | 8.4*100*2.5 | - | - | - | - | - |

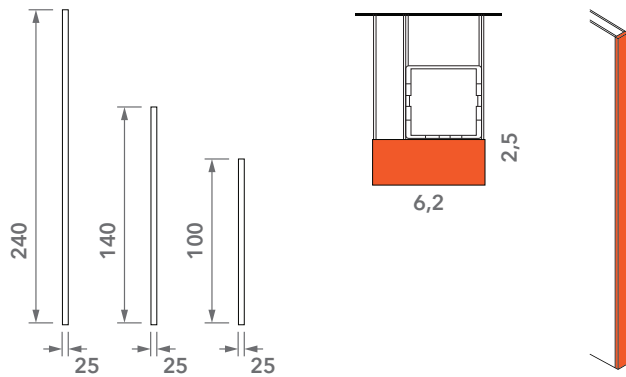

VERTICAL ENDING PRF

| Code | Stand Size | Panels | Panel Size | Max | Packing | Total |
|-----------|-------------|--------|------------|-----|---------|-------|
| | Cm | | | | | |
| BM005L01R | 6.3*240*1.5 | - | - | - | - | - |
| BM005L02R | 6.3*140*1.5 | - | - | - | - | - |
| BM005L03R | 6.3*100*1.5 | - | - | - | - | - |
| BM005L04L | 6.0*240*1.5 | - | - | - | - | - |
| BM005L05L | 6.0*140*1.5 | - | - | - | - | - |
| BM005L06L | 6.0*100*1.5 | - | - | - | - | - |

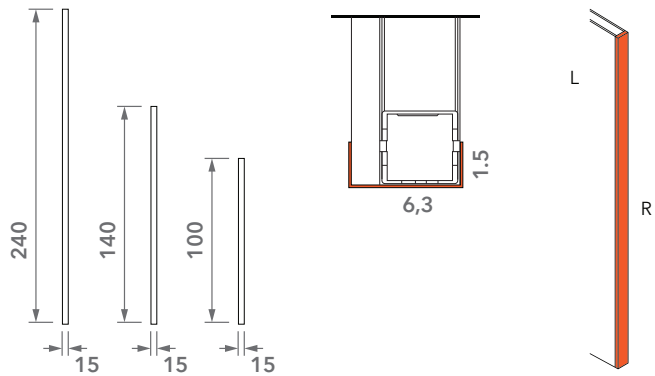

BM007LRL

VERTICAL ENDING PRF (SHEET METAL)

| Code | Stand Size | Panels | Panel Size | Max | Packing | Total |
|-----------|-------------|--------|------------|-----|---------|-------|
| | Cm | | | | | |
| BM007L01R | 7.3*240*1.5 | - | - | - | - | - |
| BM007L02R | 7.3*140*1.5 | - | - | - | - | - |
| BM007L03R | 7.3*100*1.5 | - | - | - | - | - |
| BM007L04L | 7.3*240*1.5 | - | - | - | - | - |
| BM007L05L | 7.3*140*1.5 | - | - | - | - | - |
| BM007L06L | 7.3*100*1.5 | - | - | - | - | - |

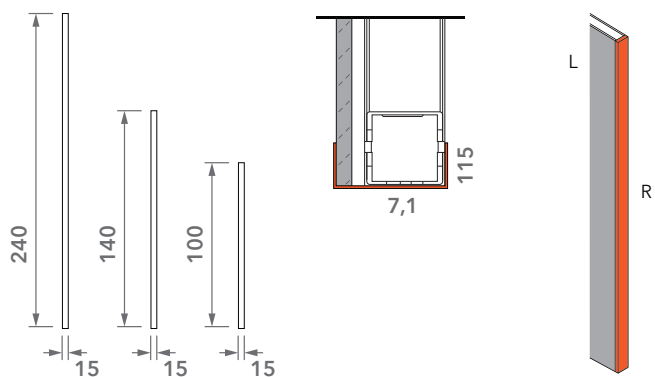

BM FRAME ENDING PRF

BM009L01

VERTICAL ENDING PRF METAL

| Code | Stand Size | Panels | Panel Size | Max | Packing | Total |
|----------|--------------|--------|------------|-----|---------|-------|
| | Cm | Qty | Cm | Kg | Cm | Kg |
| BM009L01 | 10.4*240*1.5 | - | - | - | - | - |
| BM009L02 | 10.4*140*1.5 | - | - | - | - | - |
| BM009L03 | 10.4*100*1.5 | - | - | - | - | - |

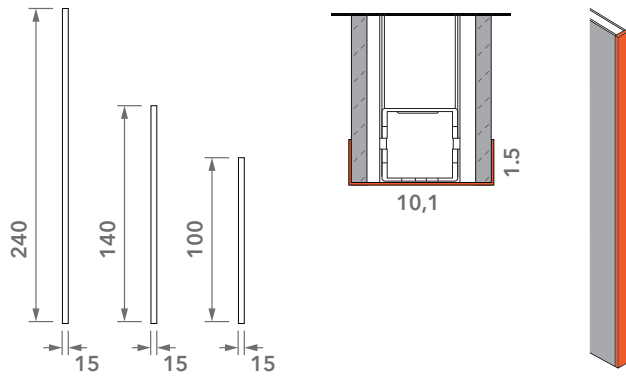

BM210G01

VERTICAL ENDING PRF MDFLAM, CHPBRDLAM

| Code | Stand Size | Panels | Panel Size | Max | Packing | Total |
|----------|-------------|--------|------------|-----|---------|-------|
| | Cm | Qty | Cm | Kg | Cm | Kg |
| BM210G01 | 9.4*240*2.5 | - | - | - | - | - |
| BM210G02 | 9.4*140*2.5 | - | - | - | - | - |
| BM210G03 | 9.4*100*2.5 | - | - | - | - | - |

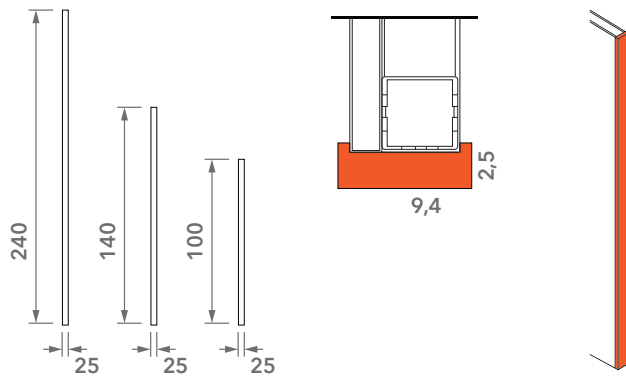

BM211G01

VERTICAL ENDING PRF MDFLAM, CHPBRDLAM

| Code | Stand Size | Panels | Panel Size | Max | Packing | Total |
|----------|-------------|--------|------------|-----|---------|-------|
| | Cm | Qty | Cm | Kg | Cm | Kg |
| BM211G01 | 6.7*240*2.5 | - | - | - | - | - |
| BM211G02 | 6.7*140*2.5 | - | - | - | - | - |
| BM211G03 | 6.7*100*2.5 | - | - | - | - | - |

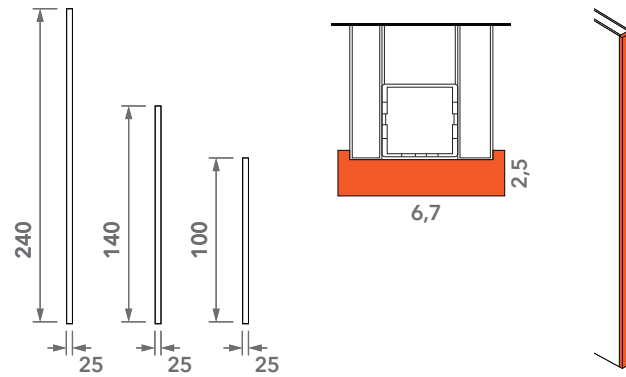

BM212G01

VERTICAL ENDING PRF MDFLAM, CHPBRDLAMT

| Code | Stand Size | Panels | Panel Size | Max | Packing | Total |
|----------|--------------|--------|------------|-----|---------|-------|
| | Cm | Qty | Cm | Kg | Cm | Kg |
| BM212G01 | 11.4*240*2.5 | - | - | - | - | - |
| BM212G02 | 11.4*140*2.5 | - | - | - | - | - |
| BM212G03 | 11.4*100*2.5 | - | - | - | - | - |

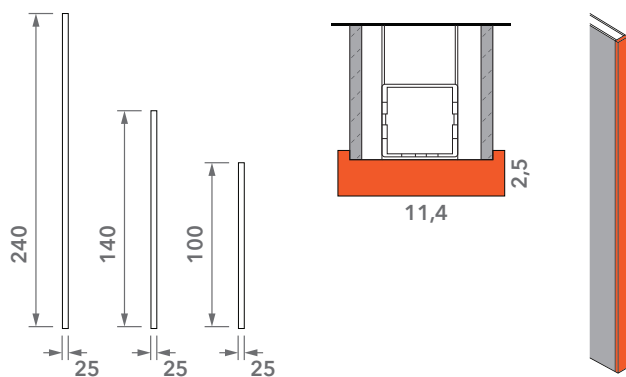

BM FRAME ENDING PRF

BM009L01

VERTICAL ENDING PRF METAL

| Code | Stand Size | Panels | Panel Size | Max | Packing | Total |
|----------|--------------|--------|------------|-----|---------|-------|
| | Cm | | | | | |
| BM009L01 | 10.4*240*1.5 | - | - | - | - | - |
| BM009L02 | 10.4*140*1.5 | - | - | - | - | - |
| BM009L03 | 10.4*100*1.5 | - | - | - | - | - |

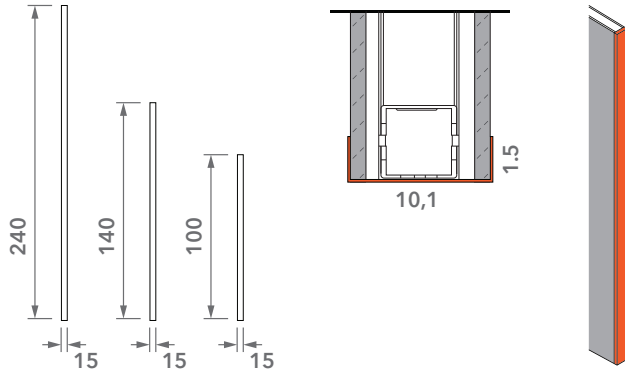

BM210I01

VERTICAL ENDING PRF MDF LACQUER

| Code | Stand Size | Panels | Panel Size | Max | Packing | Total |
|----------|-------------|--------|------------|-----|---------|-------|
| | Cm | | | | | |
| BM210I01 | 9.4*240*2.5 | - | - | - | - | - |
| BM210I02 | 9.4*140*2.5 | - | - | - | - | - |
| BM210I03 | 9.4*100*2.5 | - | - | - | - | - |

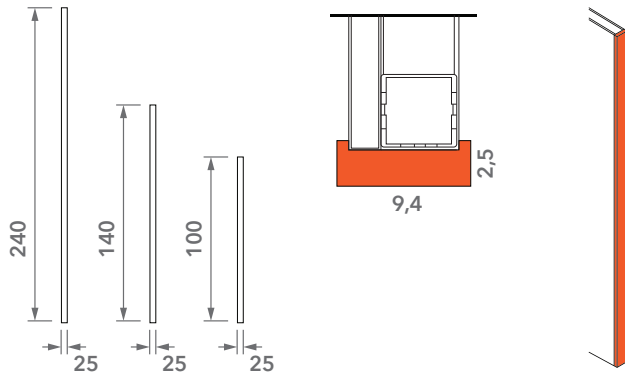

BM211I01

VERTICAL ENDING PRF MDF LACQUER

| Code | Stand Size | Panels | Panel Size | Max | Packing | Total |
|----------|-------------|--------|------------|-----|---------|-------|
| | Cm | | | | | |
| BM211I01 | 6.7*240*2.5 | - | - | - | - | - |
| BM211I02 | 6.7*140*2.5 | - | - | - | - | - |
| BM211I03 | 6.7*100*2.5 | - | - | - | - | - |

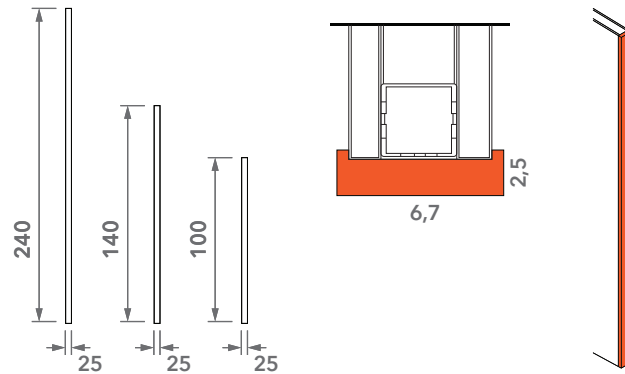

BM212I01

VERTICAL ENDING PRF MDF LACQUER

| Code | Stand Size | Panels | Panel Size | Max | Packing | Total |
|----------|--------------|--------|------------|-----|---------|-------|
| | Cm | | | | | |
| BM212I01 | 11.4*240*2.5 | - | - | - | - | - |
| BM212I02 | 11.4*140*2.5 | - | - | - | - | - |
| BM212I03 | 11.4*100*2.5 | - | - | - | - | - |

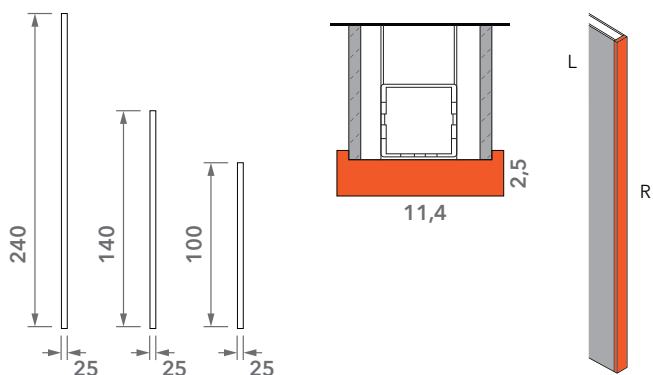

BM INNER PRF

BM002J01

INNER PRF 8X4

| Code | Stand Size | Panels | Panel Size | Max | Packing | Total |
|----------|------------|--------|------------|-----|---------|-------|
| | Cm | Qty | Cm | Kg | Cm | Kg |
| BM002J01 | 8*226 | - | - | - | - | - |
| BM002J02 | 8*138 | - | - | - | - | - |
| BM002J03 | 8*98 | - | - | - | - | - |

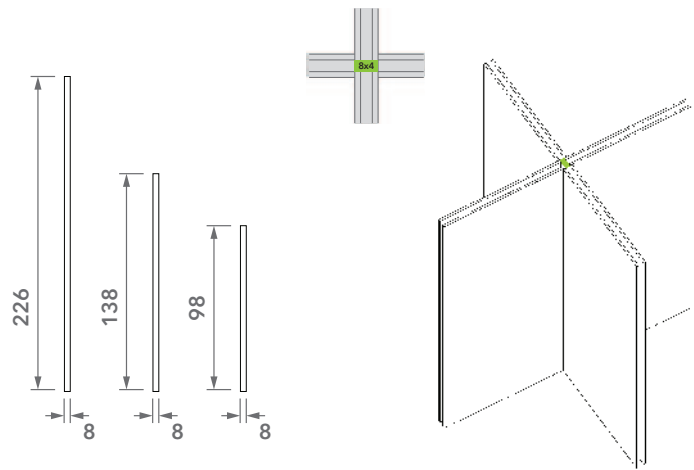

BM002J01

INNER PRF 8X4

| Code | Stand Size | Panels | Panel Size | Max | Packing | Total |
|----------|------------|--------|------------|-----|---------|-------|
| | Cm | Qty | Cm | Kg | Cm | Kg |
| BM002J01 | 8*226 | - | - | - | - | - |
| BM002J02 | 8*138 | - | - | - | - | - |
| BM002J03 | 8*98 | - | - | - | - | - |

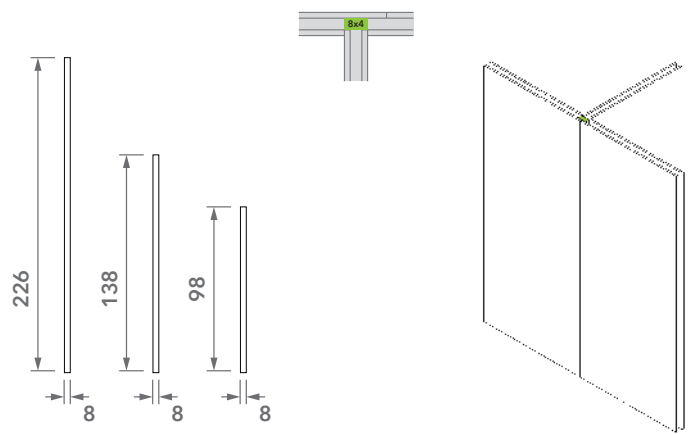

BM001J01

INNER PRF 6X4

| Code | Stand Size | Panels | Panel Size | Max | Packing | Total |
|----------|------------|--------|------------|-----|---------|-------|
| | Cm | Qty | Cm | Kg | Cm | Kg |
| BM001J01 | 6*226 | - | - | - | - | - |
| BM001J02 | 6*138 | - | - | - | - | - |
| BM001J03 | 6*98 | - | - | - | - | - |

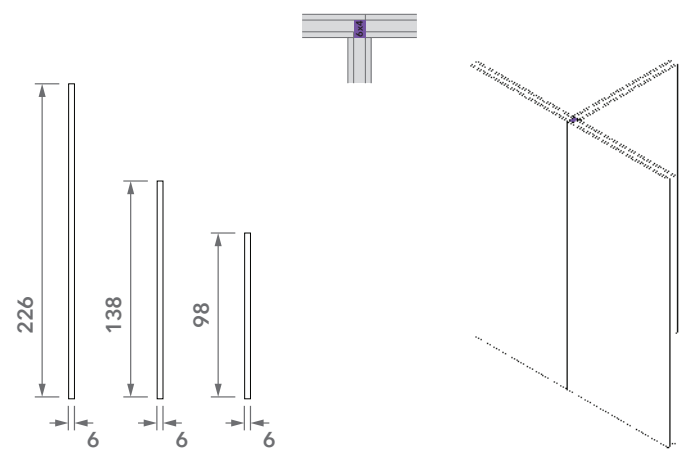

BM001J01

INNER PRF 6X4

| Code | Stand Size | Panels | Panel Size | Max | Packing | Total |
|----------|------------|--------|------------|-----|---------|-------|
| | Cm | Qty | Cm | Kg | Cm | Kg |
| BM001J01 | 6*226 | - | - | - | - | - |
| BM001J02 | 6*138 | - | - | - | - | - |
| BM001J03 | 6*98 | - | - | - | - | - |

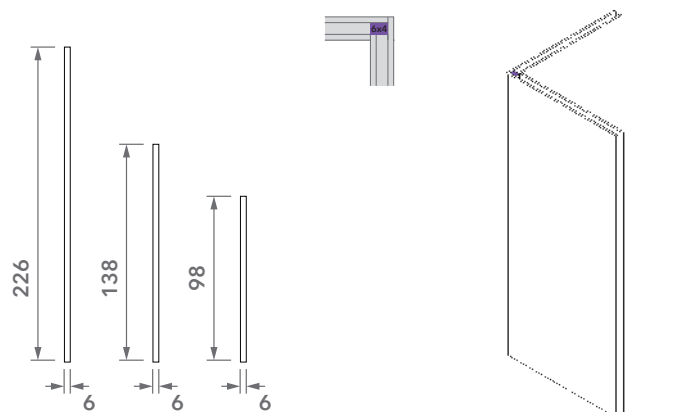

BM ADVERTISEMENT UNIT

BM001E

| Code | Stand Size | Panels | Panel Size | Max | Packing | Total |
|----------|------------|--------|------------|-----|---------|-------|
| | Cm | Qty | Cm | Kg | Cm | Kg |
| BM001E01 | 60*240*8 | - | - | - | - | - |
| BM001E02 | 60*140*8 | - | - | - | - | - |
| BM001E03 | 60*100*8 | - | - | - | - | - |

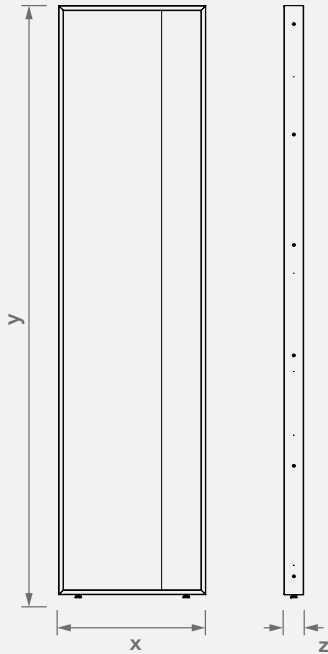

BM002E

| Code | Stand Size | Panels | Panel Size | Max | Packing | Total |
|----------|------------|--------|------------|-----|---------|-------|
| | Cm | Qty | Cm | Kg | Cm | Kg |
| BM002E01 | 80*240*8 | - | - | - | - | - |
| BM002E02 | 80*140*8 | - | - | - | - | - |
| BM002E03 | 80*100*8 | - | - | - | - | - |



BM METAL FRAME INNER PRF

BM003J01

INNER PRF PERFORATED

| Code | Stand Size | Panels | Panel Size | Max | Packing | Total |
|----------|------------|--------|------------|-----|---------|-------|
| | Cm | Qty | Cm | Kg | Cm | Kg |
| BM003J01 | 4*240*1 | - | - | - | - | - |
| BM003J02 | 4*140*1 | - | - | - | - | - |
| BM003J03 | 4*100*1 | - | - | - | - | - |

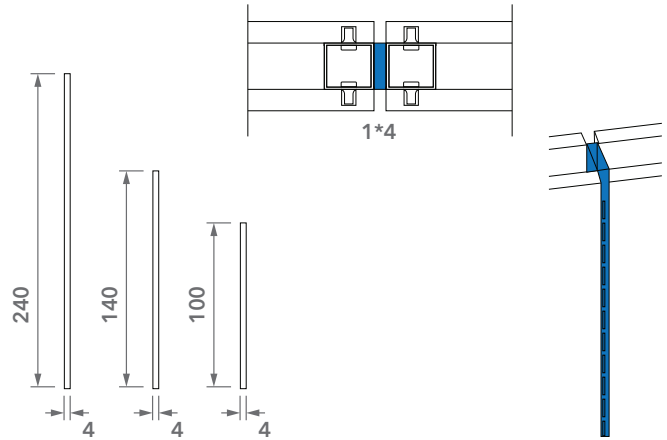

BM004J01

INNER PRF PERFORATED

| Code | Stand Size | Panels | Panel Size | Max | Packing | Total |
|----------|------------|--------|------------|-----|---------|-------|
| | Cm | Qty | Cm | Kg | Cm | Kg |
| BM004J01 | 4*240*2 | - | - | - | - | - |
| BM004J02 | 4*140*2 | - | - | - | - | - |
| BM004J03 | 4*100*2 | - | - | - | - | - |

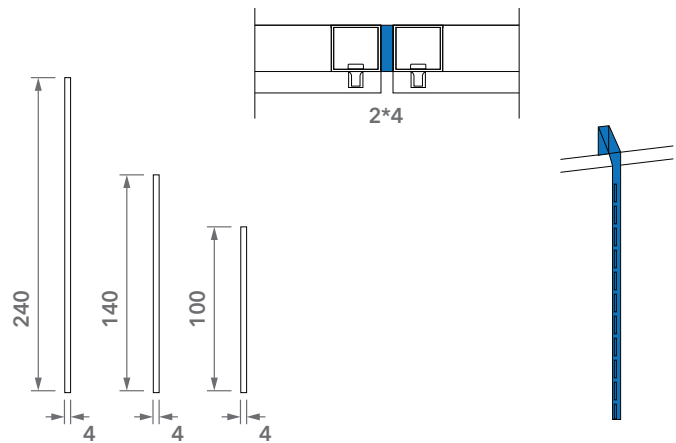

BM005J01

INNER PRF PERFORATED

| Code | Stand Size | Panels | Panel Size | Max | Packing | Total |
|----------|------------|--------|------------|-----|---------|-------|
| | Cm | Qty | Cm | Kg | Cm | Kg |
| BM005J01 | 8*240*2 | - | - | - | - | - |
| BM005J02 | 8*140*2 | - | - | - | - | - |
| BM005J03 | 8*100*2 | - | - | - | - | - |

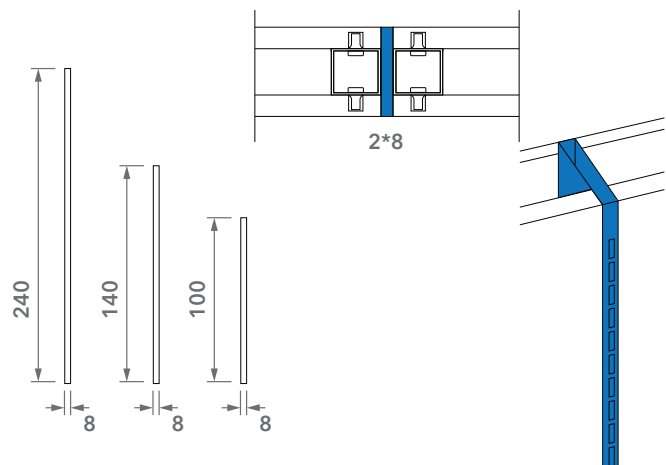

BM006J01

INNER PRF PERFORATED

| Code | Stand Size | Panels | Panel Size | Max | Packing | Total |
|----------|------------|--------|------------|-----|---------|-------|
| | Cm | Qty | Cm | Kg | Cm | Kg |
| BM006J01 | 6*240*2 | - | - | - | - | - |
| BM006J02 | 6*140*2 | - | - | - | - | - |
| BM006J03 | 6*100*2 | - | - | - | - | - |

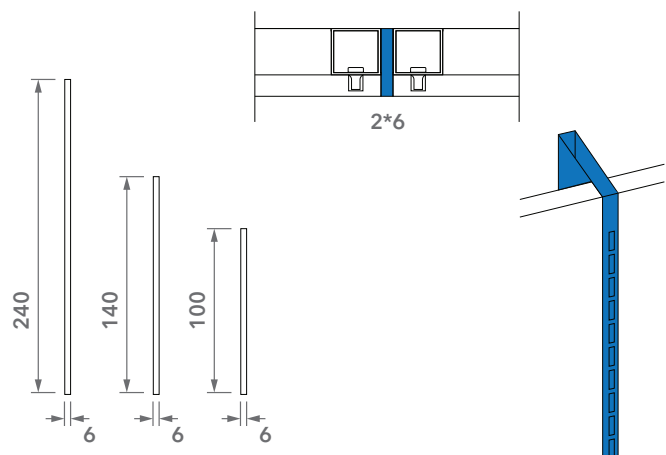

BM STANDS



BM001A

STANDS

| Code | Stand Size | Panels | Panel Size | Max | Packing | Total |
|----------|-------------|--------|------------|-----|---------|-------|
| | Cm | Qty | Cm | | Cm | |
| BM001A03 | 44*240*142 | 3 | 101*193 | - | - | - |
| BM001A05 | 64*240*142 | 5 | 101*193 | - | - | - |
| BM001A06 | 74*240*142 | 6 | 101*193 | - | - | - |
| BM001A08 | 94*240*142 | 8 | 101*193 | - | - | - |
| BM001A10 | 114*240*142 | 10 | 101*193 | - | - | - |
| BM001A23 | 44*240*142 | 3 | 101*201 | - | - | - |
| BM001A25 | 64*240*142 | 5 | 101*201 | - | - | - |
| BM001A26 | 74*240*142 | 6 | 101*201 | - | - | - |
| BM001A28 | 94*240*142 | 8 | 101*201 | - | - | - |
| BM001A30 | 114*240*142 | 10 | 101*201 | - | - | - |

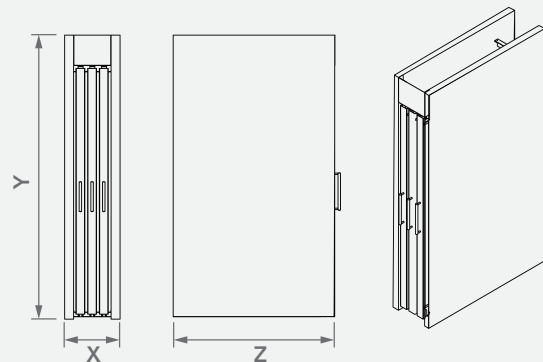

BM STANDS



BM003A

STANDS

| Code | Stand Size | Panels | Panel Size | Max | Packing | Total |
|----------|-------------|--------|------------|-----|---------|-------|
| | Cm | | Qty | | Cm | |
| BM003A03 | 44*240*142 | 3 | 101*193 | - | - | - |
| BM003A05 | 64*240*142 | 5 | 101*193 | - | - | - |
| BM003A06 | 74*240*142 | 6 | 101*193 | - | - | - |
| BM003A08 | 94*240*142 | 8 | 101*193 | - | - | - |
| BM003A10 | 114*240*142 | 10 | 101*193 | - | - | - |
| BM003A23 | 44*240*142 | 3 | 101*201 | - | - | - |
| BM003A25 | 64*240*142 | 5 | 101*201 | - | - | - |
| BM003A26 | 74*240*142 | 6 | 101*201 | - | - | - |
| BM003A28 | 94*240*142 | 8 | 101*201 | - | - | - |
| BM003A30 | 114*240*142 | 10 | 101*201 | - | - | - |

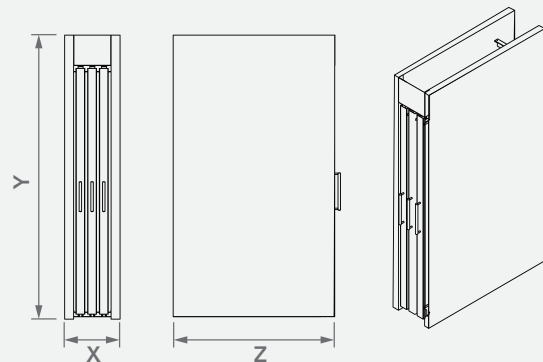

PULL OUT, ROTATING

MATRIX COMPONENTS

BM, BW

COMPONENTS

BW Series
BM Series

COMPONENTS

BW TECHNICAL WALL COMPONENTS

BW019M

| Code | Stand Size | Panels | Panel Size | Max | Packing | Total |
|----------|------------|--------|------------|-----|---------|-------|
| | Cm | Qty | Cm | Kg | Cm | Kg |
| BW019M01 | 20*34*28 | 3 | 45*60 | - | - | - |
| BW019M02 | 40*34*28 | 6 | 45*60 | - | - | - |
| BW019M03 | 60*34*28 | 9 | 45*60 | - | - | - |
| BW019M04 | 80*34*28 | 12 | 45*60 | - | - | - |

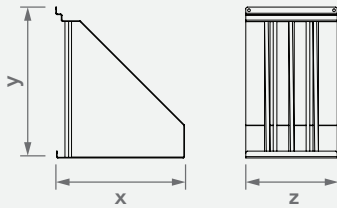

BW020M

| Code | Stand Size | Panels | Panel Size | Max | Packing | Total |
|----------|------------|--------|------------|-----|---------|-------|
| | Cm | Qty | Cm | Kg | Cm | Kg |
| BW020M01 | 20*40*40 | 3 | 60*60 | - | - | - |
| BW020M02 | 40*40*40 | 6 | 60*60 | - | - | - |
| BW020M03 | 60*40*40 | 9 | 60*60 | - | - | - |
| BW020M04 | 80*40*40 | 12 | 60*60 | - | - | - |

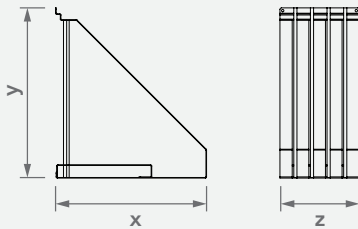

BW021M

| Code | Stand Size | Panels | Panel Size | Max | Packing | Total |
|----------|------------|--------|------------|-----|---------|-------|
| | Cm | Qty | Cm | Kg | Cm | Kg |
| BW021M01 | 43*199 | 6 | 30*60 | - | - | - |

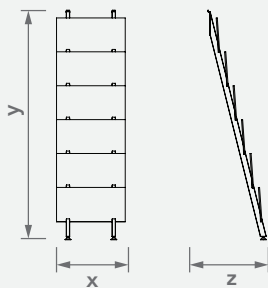

BW TECHNICAL WALL COMPONENTS

BW022M

| Code | Stand Size | Panels | Panel Size | Max | Packing | Total |
|----------|------------|--------|------------|-----|---------|-------|
| | Cm | Qty | Cm | Kg | Cm | Kg |
| BW022M01 | 42*135*40 | 8 | 30*60 | - | - | - |
| BW022M02 | 42*90*40 | 5 | 30*60 | - | - | - |

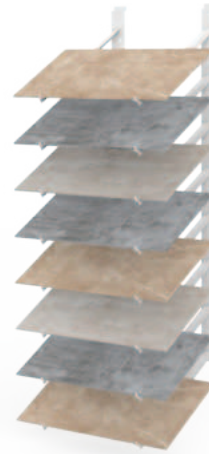
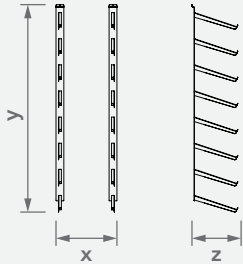

BW023M

| Code | Stand Size | Panels | Panel Size | Max | Packing | Total |
|----------|------------|--------|------------|-----|---------|-------|
| | Cm | Qty | Cm | Kg | Cm | Kg |
| BW023M01 | 30*30*30 | - | - | - | - | - |
| BW023M02 | 60*30*30 | - | - | - | - | - |

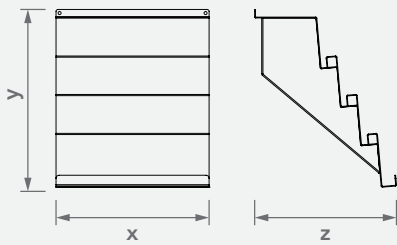

BW024N

| Code | Stand Size | Panels | Panel Size | Max | Packing | Total |
|----------|------------|--------|------------|-----|---------|-------|
| | Cm | Qty | Cm | Kg | Cm | Kg |
| BW024N01 | 80*30*30 | - | - | - | - | - |

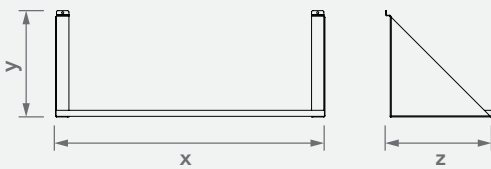

BW025M

| Code | Stand Size | Panels | Panel Size | Max | Packing | Total |
|----------|--------------|--------|------------|-----|---------|-------|
| | Cm | Qty | Cm | Kg | Cm | Kg |
| BW025M01 | 36.6*34.6*25 | - | 3 | - | - | - |

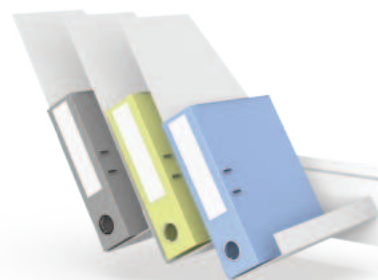
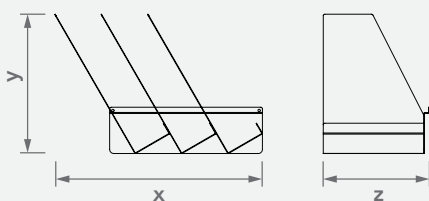

BW026S

| Code | Stand Size | Panels | Panel Size | Max | Packing | Total |
|----------|------------|--------|------------|-----|---------|-------|
| | Cm | Qty | Cm | Kg | Cm | Kg |
| BW026S01 | 60*20*40 | 6 | - | - | - | - |
| BW026S02 | 80*20*40 | 6 | - | - | - | - |
| BW026S03 | 100*20*40 | 6 | - | - | - | - |

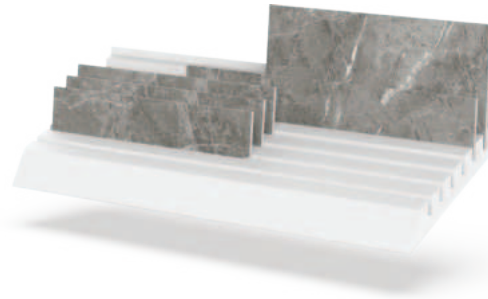
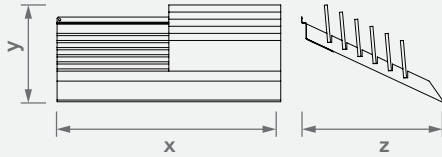

BW027S

| Code | Stand Size | Panels | Panel Size | Max | Packing | Total |
|----------|------------|--------|------------|-----|---------|-------|
| | Cm | Qty | Cm | Kg | Cm | Kg |
| BW027S01 | 51*20*17 | 7 | 30*30 | - | - | - |

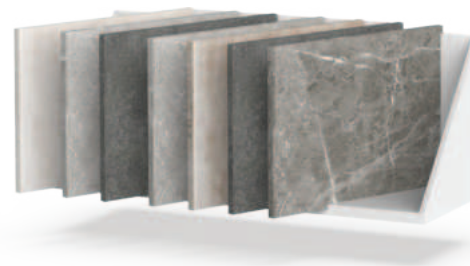
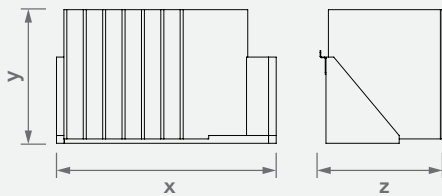

BW028S

| Code | Stand Size | Panels | Panel Size | Max | Packing | Total |
|----------|------------|--------|------------|-----|---------|-------|
| | Cm | Qty | Cm | Kg | Cm | Kg |
| BW028S01 | 68*5*36 | 3 | 60*60 | - | - | - |

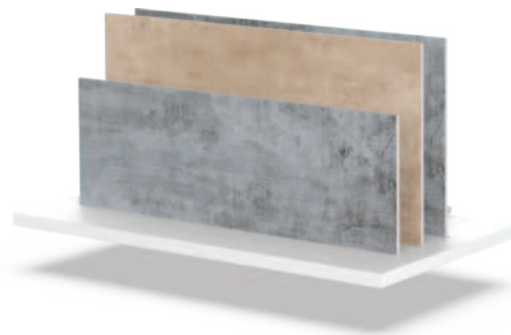
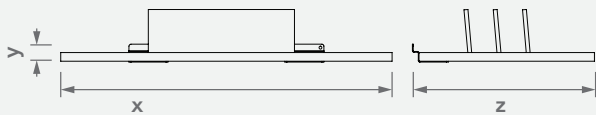

BW029M

| Code | Stand Size | Panels | Panel Size | Max | Packing | Total |
|----------|------------|--------|------------|-----|---------|-------|
| | Cm | Qty | Cm | Kg | Cm | Kg |
| BW029M01 | 80*23*87 | 2 | - | - | - | - |
| BW029M02 | 100*23*87 | 6 | - | - | - | - |

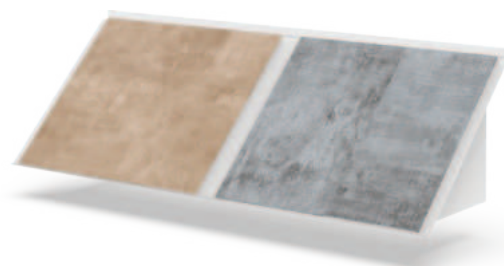
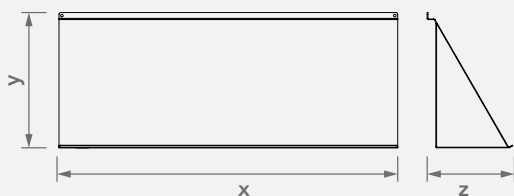

BW030M

| Code | Stand Size | Panels | Panel Size | Max | Packing | Total |
|----------|------------|--------|------------|-----|---------|-------|
| | Cm | Qty | Cm | Kg | Cm | Kg |
| BW030M01 | 87*11*62 | 1 | - | - | - | - |

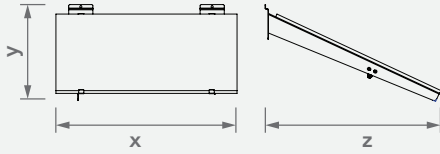

BW031M

| Code | Stand Size | Panels | Panel Size | Max | Packing | Total |
|----------|------------|--------|------------|-----|---------|-------|
| | Cm | Qty | Cm | Kg | Cm | Kg |
| BW031M01 | 20*12 | 1 | - | - | - | - |
| BW031M02 | 40*12 | 1 | - | - | - | - |

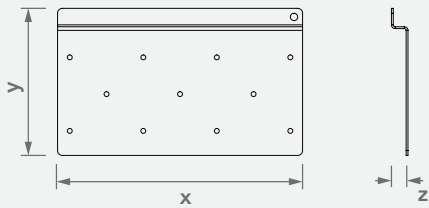

BW032S

| Code | Stand Size | Panels | Panel Size | Max | Packing | Total |
|----------|------------|--------|------------|-----|---------|-------|
| | Cm | Qty | Cm | Kg | Cm | Kg |
| BW032S01 | 20*40*40 | - | - | - | - | - |

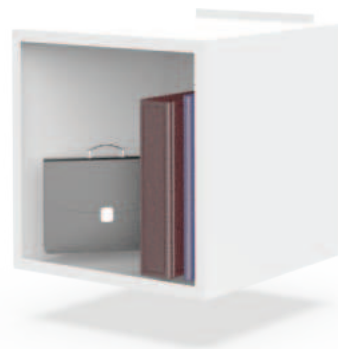
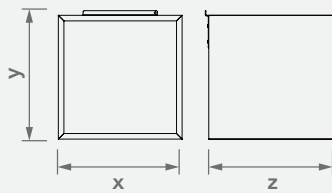

BW033N

| Code | Stand Size | Panels | Panel Size | Max | Packing | Total |
|----------|------------|--------|------------|-----|---------|-------|
| | Cm | Qty | Cm | Kg | Cm | Kg |
| BW033N01 | 40*40*40 | 6 | - | - | - | - |
| BW033N02 | 80*40*40 | 6 | - | - | - | - |

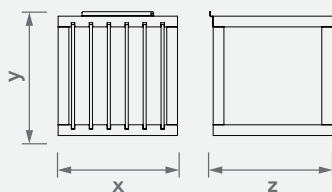

BW TECHNICAL WALL COMPONENTS

BW034M

| Code | Stand Size | Panels | Panel Size | Max | Packing | Total |
|----------|------------|--------|------------|-----|---------|-------|
| | Cm | Qty | Cm | Kg | Cm | Kg |
| BW034M01 | 15*32*30 | 1 | - | - | - | - |
| BW034M02 | 17*32*30 | 1 | - | - | - | - |
| BW034M03 | 30*32*30 | 1 | - | - | - | - |
| BW034M04 | 33*32*30 | 1 | - | - | - | - |

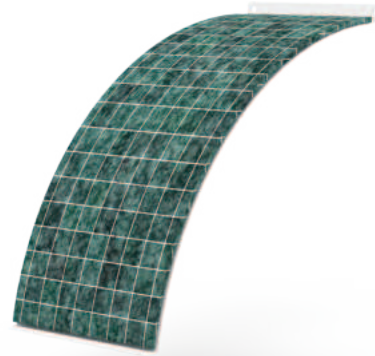
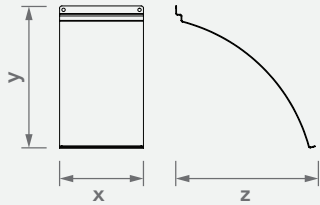

BW035M

| Code | Stand Size | Panels | Panel Size | Max | Packing | Total |
|----------|------------|--------|------------|-----|---------|-------|
| | Cm | Qty | Cm | Kg | Cm | Kg |
| BW035M01 | 15*25*29 | 1 | - | - | - | - |
| BW035M02 | 17*25*29 | 1 | - | - | - | - |
| BW035M03 | 30*25*29 | 1 | 30*30 | - | - | - |
| BW035M04 | 33*25*29 | 1 | 33*30 | - | - | - |

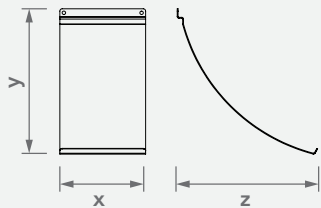

BW036M

| Code | Stand Size | Panels | Panel Size | Max | Packing | Total |
|----------|------------|--------|------------|-----|---------|-------|
| | Cm | Qty | Cm | Kg | Cm | Kg |
| BW036M01 | 15*19*26 | 1 | - | - | - | - |
| BW036M02 | 17*19*26 | 1 | - | - | - | - |
| BW036M03 | 30*19*26 | 1 | - | - | - | - |
| BW036M04 | 33*19*26 | 1 | - | - | - | - |

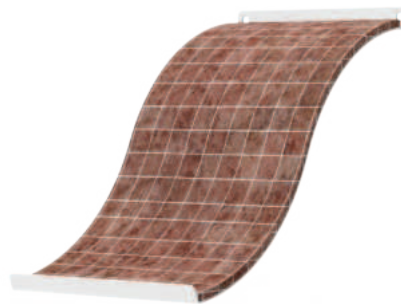
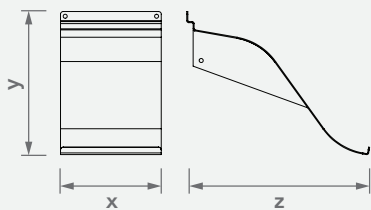

BW037M

| Code | Stand Size | Panels | Panel Size | Max | Packing | Total |
|----------|------------|--------|------------|-----|---------|-------|
| | Cm | Qty | Cm | Kg | Cm | Kg |
| BW037M01 | 15*15*66 | 1 | - | - | - | - |
| BW037M02 | 17*15*66 | 1 | - | - | - | - |
| BW037M03 | 30*15*66 | 1 | - | - | - | - |
| BW037M04 | 33*15*66 | 1 | - | - | - | - |

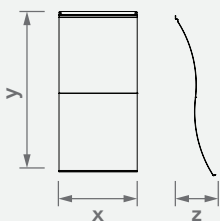

BW038M

| Code | Stand Size | Panels | Panel Size | Max | Packing | Total |
|----------|------------|--------|------------|-----|---------|-------|
| | Cm | Qty | Cm | Kg | Cm | Kg |
| BW038M01 | 15*19*25 | 1 | - | - | - | - |
| BW038M02 | 17*19*25 | 1 | - | - | - | - |
| BW038M03 | 30*19*25 | 1 | - | - | - | - |
| BW038M04 | 33*19*25 | 1 | - | - | - | - |

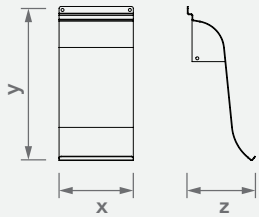

BW039M

| Code | Stand Size | Panels | Panel Size | Max | Packing | Total |
|----------|------------|--------|------------|-----|---------|-------|
| | Cm | Qty | Cm | Kg | Cm | Kg |
| BW039M01 | 30*42*25 | 1 | - | - | - | - |
| BW039M02 | 40*42*25 | 1 | - | - | - | - |
| BW039M03 | 60*42*25 | 1 | - | - | - | - |

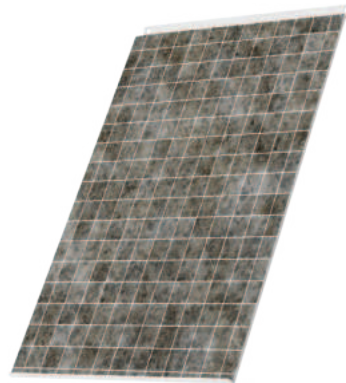
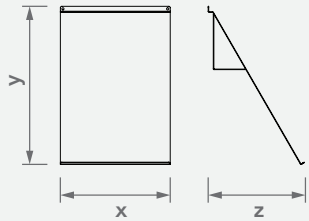

BW040M

| Code | Stand Size | Panels | Panel Size | Max | Packing | Total |
|----------|------------|--------|------------|-----|---------|-------|
| | Cm | Qty | Cm | Kg | Cm | Kg |
| BW040M01 | 15*31*18 | 1 | - | - | - | - |
| BW040M02 | 17*31*18 | 1 | - | - | - | - |
| BW040M03 | 30*31*18 | 1 | - | - | - | - |
| BW040M04 | 33*31*18 | 1 | - | - | - | - |

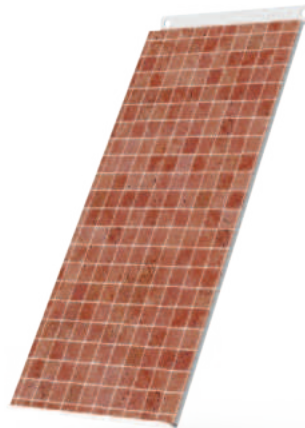
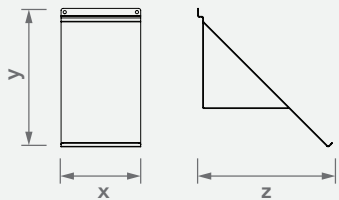

BW041N

| Code | Stand Size | Panels | Panel Size | Max | Packing | Total |
|----------|------------|--------|------------|-----|---------|-------|
| | Cm | Qty | Cm | Kg | Cm | Kg |
| BW041N01 | 60*63*40 | 1 | - | - | - | - |
| BW041N02 | 70*63*40 | 1 | - | - | - | - |
| BW041N03 | 80*63*40 | 1 | - | - | - | - |

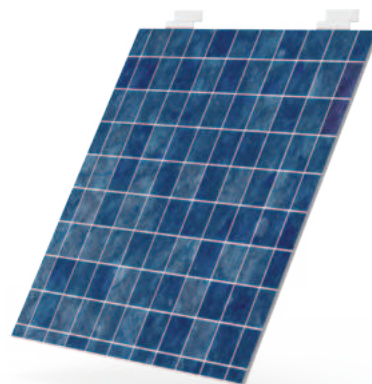
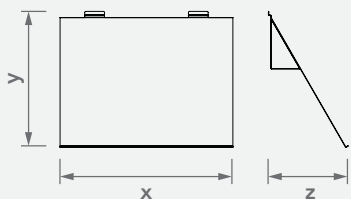

BW TECHNICAL WALL COMPONENTS

BW042M

| Code | Stand Size | Panels | Panel Size | Max | Packing | Total |
|----------|--------------|--------|------------|-----|---------|-------|
| | Cm | Qty | Cm | Kg | Cm | Kg |
| BW042M01 | 68*19.5*19.5 | 2 | 68*40 | - | - | - |

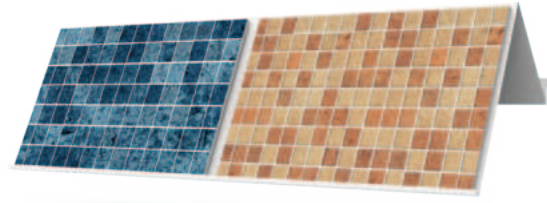
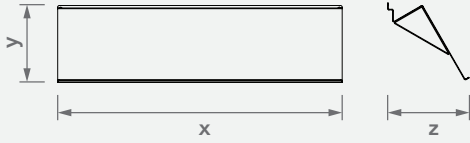

BW043P

| Code | Stand Size | Panels | Panel Size | Max | Packing | Total |
|----------|------------|--------|------------|-----|---------|-------|
| | Cm | Qty | Cm | Kg | Cm | Kg |
| BW043P01 | 25*21*3 | - | 21*30 | - | - | - |

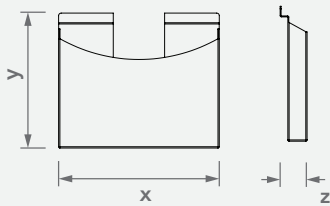

BW044M

| Code | Stand Size | Panels | Panel Size | Max | Packing | Total |
|----------|------------|--------|------------|-----|---------|-------|
| | Cm | Qty | Cm | Kg | Cm | Kg |
| BW044M01 | 15*31*18 | 1 | - | - | - | - |

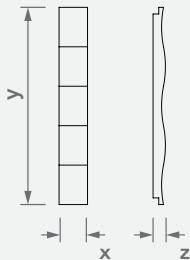

BW045M

| Code | Stand Size | Panels | Panel Size | Max | Packing | Total |
|----------|------------|--------|------------|-----|---------|-------|
| | Cm | Qty | Cm | Kg | Cm | Kg |
| BW045M01 | 33*183*40 | 1 | - | - | - | - |

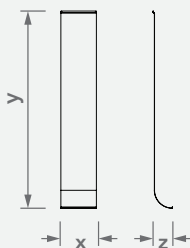

BW046M

| Code | Stand Size | Panels | Panel Size | Max | Packing | Total |
|----------|------------|--------|------------|-----|---------|-------|
| | Cm | Qty | Cm | Kg | Cm | Kg |
| BW046M01 | 5*33*21 | 8 | - | - | - | - |
| BW046M02 | 5*45.5*31 | 12 | - | - | - | - |

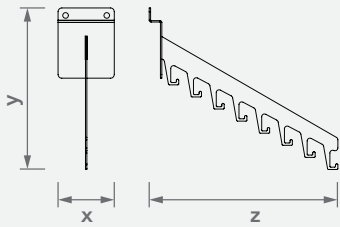

BW047M

| Code | Stand Size | Panels | Panel Size | Max | Packing | Total |
|----------|------------|--------|------------|-----|---------|-------|
| | Cm | Qty | Cm | Kg | Cm | Kg |
| BW047M01 | 6*11*36 | 6 | - | - | - | - |
| BW047M02 | 6*11*51 | 10 | - | - | - | - |

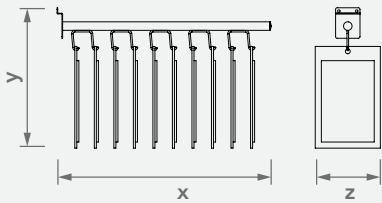

BW048M

| Code | Stand Size | Panels | Panel Size | Max | Packing | Total |
|----------|------------|--------|------------|-----|---------|-------|
| | Cm | Qty | Cm | Kg | Cm | Kg |
| BW048M01 | 10*9*3 | 1 | 210*30 | - | - | - |

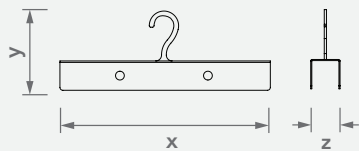

BW049M

| Code | Stand Size | Panels | Panel Size | Max | Packing | Total |
|----------|------------|--------|------------|-----|---------|-------|
| | Cm | Qty | Cm | Kg | Cm | Kg |
| BW049M01 | 60*63*40 | 1 | 210*40 | - | - | - |

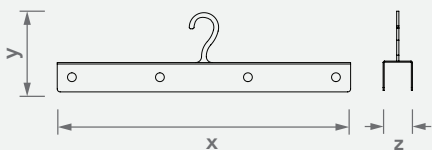

BW TECHNICAL WALL COMPONENTS

BW050M

| Code | Stand Size | Panels | Panel Size | Max | Packing | Total |
|----------|------------|--------|------------|-----|---------|-------|
| | Cm | Qty | Cm | Kg | Cm | Kg |
| BW050M01 | 35*10*0.3 | 1 | - | - | - | - |

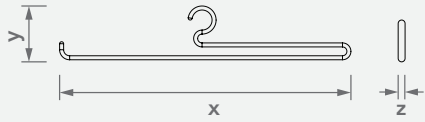

BW051M

| Code | Stand Size | Panels | Panel Size | Max | Packing | Total |
|----------|------------|--------|------------|-----|---------|-------|
| | Cm | Qty | Cm | Kg | Cm | Kg |
| BW051M01 | 51*20*27 | - | - | - | - | - |

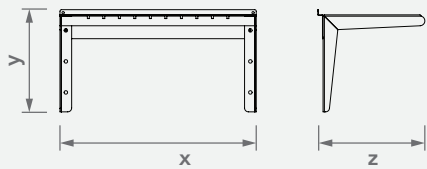

BW052M

| Code | Stand Size | Panels | Panel Size | Max | Packing | Total |
|----------|--------------|--------|------------|-----|---------|-------|
| | Cm | Qty | Cm | Kg | Cm | Kg |
| BW052M01 | 30*40.6*52.5 | 8*2 | - | - | - | - |

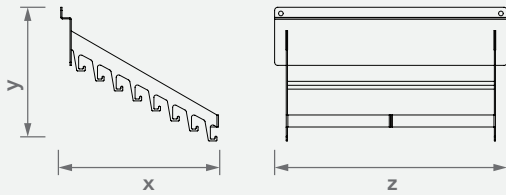

BW054M

| Code | Stand Size | Panels | Panel Size | Max | Packing | Total |
|----------|------------|--------|------------|-----|---------|-------|
| | Cm | Qty | Cm | Kg | Cm | Kg |
| BW054M01 | 20*42*47 | 1 | 60*45 | - | - | - |
| BW054M02 | 34*32*56 | 1 | 60*60 | - | - | - |

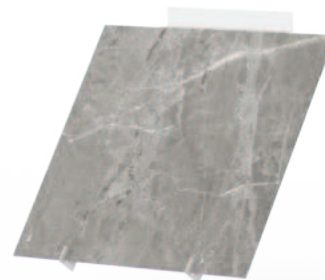
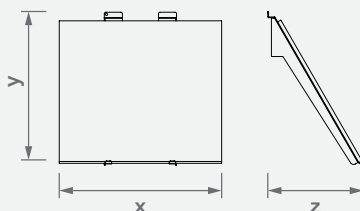

BW TECHNICAL WALL COMPONENTS

BW055M

| Code | Stand Size | Panels | Panel Size | Max | Packing | Total |
|----------|------------|--------|------------|-----|---------|-------|
| | Cm | Qty | Cm | Kg | Cm | Kg |
| BW055M01 | 20*75*25 | 5 | 30*30 | - | - | - |

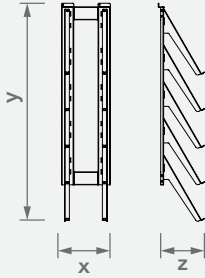

BW056M

| Code | Stand Size | Panels | Panel Size | Max | Packing | Total |
|----------|------------|--------|------------|-----|---------|-------|
| | Cm | Qty | Cm | Kg | Cm | Kg |
| BW056M01 | 35*104*45 | 5 | 60*60 | - | - | - |

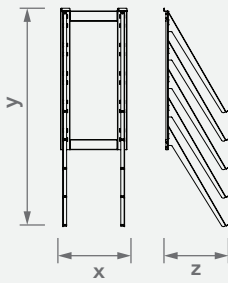

BW067M

| Code | Stand Size | Panels | Panel Size | Max | Packing | Total |
|----------|------------|--------|------------|-----|---------|-------|
| | Cm | Qty | Cm | Kg | Cm | Kg |
| BW067M08 | 7*4*3 | - | - | - | - | - |

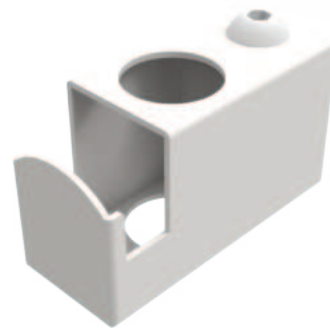
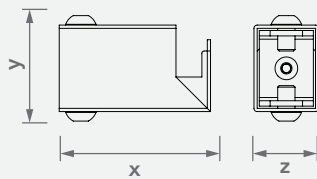

BW TECHNICAL WALL COMPONENTS

BW060M

| Code | Stand Size | Panels | Panel Size | Max | Packing | Total |
|----------|------------|--------|------------|-----|---------|-------|
| | Cm | Qty | Cm | Kg | Cm | Kg |
| BW060M01 | 40*200*4 | 1 | - | - | - | - |
| BW060M02 | 60*200*4 | 1 | - | - | - | - |

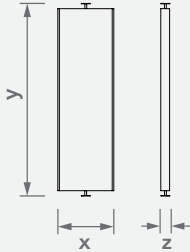

BW061M

| Code | Stand Size | Panels | Panel Size | Max | Packing | Total |
|----------|------------|--------|------------|-----|---------|-------|
| | Cm | Qty | Cm | Kg | Cm | Kg |
| BW061M01 | 30*42*25 | 4 | 30*30 | - | - | - |

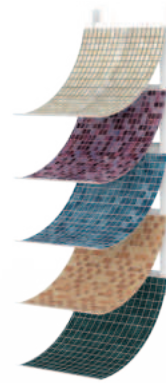
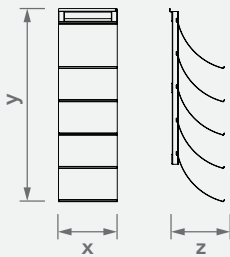

BW062M

| Code | Stand Size | Panels | Panel Size | Max | Packing | Total |
|----------|------------|--------|------------|-----|---------|-------|
| | Cm | Qty | Cm | Kg | Cm | Kg |
| BW062M01 | 70*230 | 20 | 65*90 | - | - | - |

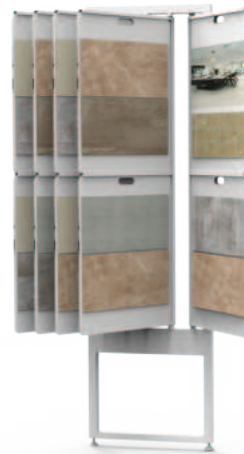
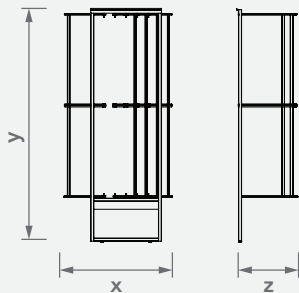

BW063M

| Code | Stand Size | Panels | Panel Size | Max | Packing | Total |
|----------|------------|--------|------------|-----|---------|-------|
| | Cm | Qty | Cm | Kg | Cm | Kg |
| BW063M01 | 26*162*70 | 12 | 60*60 | - | - | - |

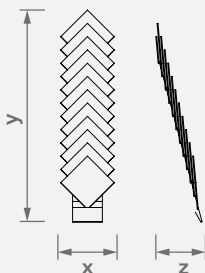

BW102N

| Code | Stand Size | Panels | Panel Size | Max | Packing | Total |
|----------|------------|--------|------------|-----|---------|-------|
| | Cm | Qty | Cm | Kg | Cm | Kg |
| BW102N01 | 60*202*4 | 1 | - | - | - | - |
| BW102N02 | 80*202*4 | 1 | - | - | - | - |
| BW102N03 | 100*202*4 | 1 | - | - | - | - |

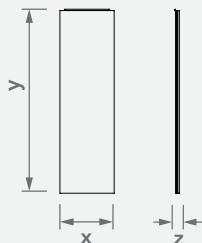

BW104N

| Code | Stand Size | Panels | Panel Size | Max | Packing | Total |
|----------|------------|--------|------------|-----|---------|-------|
| | Cm | Qty | Cm | Kg | Cm | Kg |
| BW104N01 | 60*60*1 | 1 | - | - | - | - |

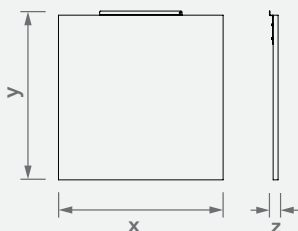

BW106N

| Code | Stand Size | Panels | Panel Size | Max | Packing | Total |
|----------|------------|--------|------------|-----|---------|-------|
| | Cm | Qty | Cm | Kg | Cm | Kg |
| BW106N01 | 60*152*1 | 1 | - | - | - | - |

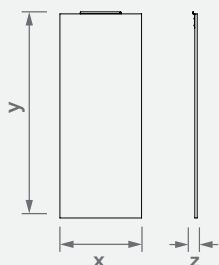

BW108N

| Code | Stand Size | Panels | Panel Size | Max | Packing | Total |
|----------|------------|--------|------------|-----|---------|-------|
| | Cm | Qty | Cm | Kg | Cm | Kg |
| BW108N01 | 40*3*21 | 1 | - | - | - | - |
| BW108N02 | 60*3*21 | 1 | - | - | - | - |
| BW108N03 | 80*3*21 | 1 | - | - | - | - |

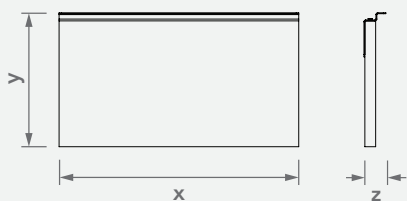

BW110N

| Code | Stand Size | Panels | Panel Size | Max | Packing | Total |
|----------|--------------|--------|------------|-----|---------|-------|
| | Cm | Qty | Cm | Kg | Cm | Kg |
| BW110N01 | 40*13.5*13.5 | 1 | - | - | - | - |

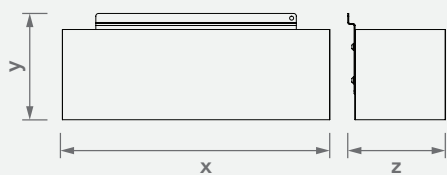

BW112N

| Code | Stand Size | Panels | Panel Size | Max | Packing | Total |
|----------|--------------|--------|------------|-----|---------|-------|
| | Cm | Qty | Cm | Kg | Cm | Kg |
| BW112N01 | 60*13.5*13.5 | 1 | - | - | - | - |



BW120N

SHELF FOR ARMATURE

| Code | Stand Size | Panels | Panel Size | Max | Packing | Total |
|----------|------------|--------|------------|-----|---------|-------|
| | Cm | Qty | Cm | Kg | Cm | Kg |
| BW120N01 | 60*40*40 | 1 | - | - | - | - |

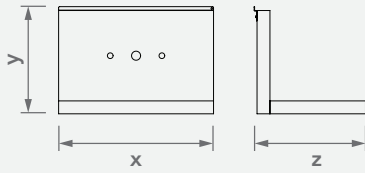

BW122N

SHELF FOR ARMATURE SHOWER

| Code | Stand Size | Panels | Panel Size | Max | Packing | Total |
|----------|------------|--------|------------|-----|---------|-------|
| | Cm | Qty | Cm | Kg | Cm | Kg |
| BW122N01 | 42*140*2.5 | 1 | - | - | - | - |

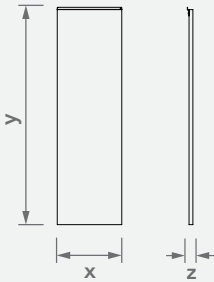

BW124N

SHELF FOR SINK

| Code | Stand Size | Panels | Panel Size | Max | Packing | Total |
|----------|------------|--------|------------|-----|---------|-------|
| | Cm | Qty | Cm | Kg | Cm | Kg |
| BW124N01 | 60*10*42 | 1 | - | - | - | - |

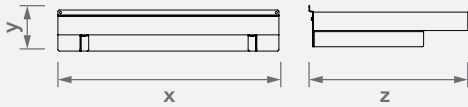

BW126N

ANGLED SHELF FOR SINK

| Code | Stand Size | Panels | Panel Size | Max | Packing | Total |
|----------|------------|--------|------------|-----|---------|-------|
| | Cm | Qty | Cm | Kg | Cm | Kg |
| BW126N01 | 60*27.5*42 | 1 | - | - | - | - |

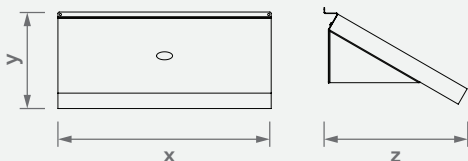

BW128M

PLAIN SHEET METAL PANEL

| Code | Stand Size | Panels | Panel Size | Max | Packing | Total |
|----------|------------|--------|------------|-----|---------|-------|
| | Cm | Qty | Cm | Kg | Cm | Kg |
| BW128M01 | 60*120*1 | 1 | - | - | - | - |

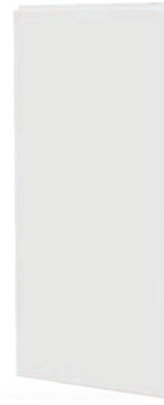
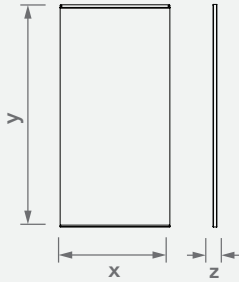

BW130M

PERFERETED SHEET METAL PANEL

| Code | Stand Size | Panels | Panel Size | Max | Packing | Total |
|----------|------------|--------|------------|-----|---------|-------|
| | Cm | Qty | Cm | Kg | Cm | Kg |
| BW130M01 | 60*120*1 | 1 | - | - | - | - |

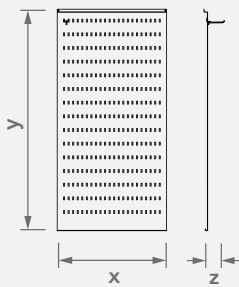

BW160N

TABLE

| Code | Stand Size | Panels | Panel Size | Max | Packing | Total |
|----------|------------|--------|------------|-----|---------|-------|
| | Cm | Qty | Cm | Kg | Cm | Kg |
| BW160N01 | 140*80*75 | - | - | - | - | - |

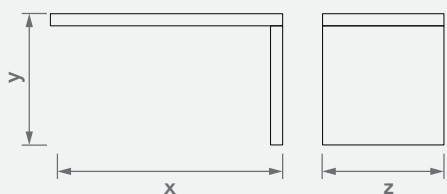

BW162N

TABLE

| Code | Stand Size | Panels | Panel Size | Max | Packing | Total |
|----------|------------|--------|------------|-----|---------|-------|
| | Cm | Qty | Cm | Kg | Cm | Kg |
| BW162N01 | 140*85*75 | - | - | - | - | - |

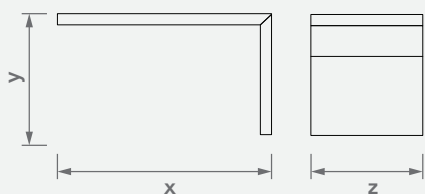

BW164N

TABLE MOBILE

| Code | Stand Size | Panels | Panel Size | Max | Packing | Total |
|----------|-------------|--------|------------|-----|---------|-------|
| | Cm | Qty | Cm | Kg | Cm | Kg |
| BW164N01 | 140*85.5*75 | - | - | - | - | - |

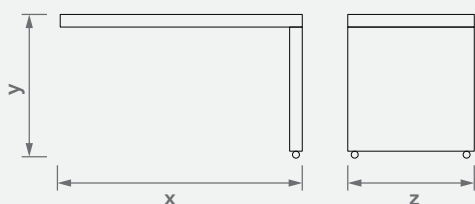

BW166N

TABLE MOBILE

| Code | Stand Size | Panels | Panel Size | Max | Packing | Total |
|----------|-------------|--------|------------|-----|---------|-------|
| | Cm | Qty | Cm | Kg | Cm | Kg |
| BW166N01 | 140*88.5*75 | - | - | - | - | - |

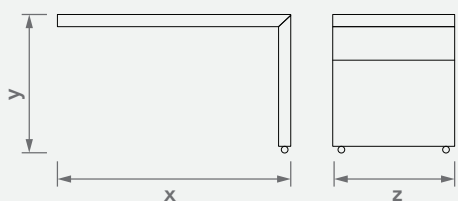

BW180M

LIGHTING SYSTEM ROUNDED (ESCARGOT)

| Code | Stand Size | Panels | Panel Size | Max | Packing | Total |
|----------|------------|--------|------------|-----|---------|-------|
| | Cm | Qty | Cm | Kg | Cm | Kg |
| BW180M01 | 30*16*50 | - | - | - | - | - |

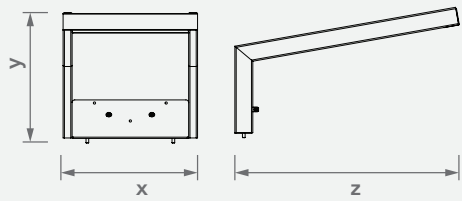

BW182M

LIGHTING SYSTEM LINEER

| Code | Stand Size | Panels | Panel Size | Max | Packing | Total |
|----------|------------|--------|------------|-----|---------|-------|
| | Cm | Qty | Cm | Kg | Cm | Kg |
| BW182M01 | 30*20*68 | - | - | - | - | - |

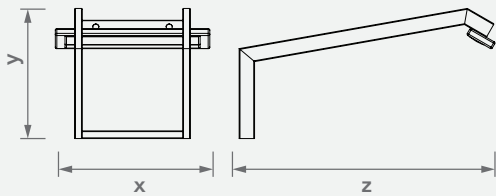

BW184M

LIGHTING SYSTEM STRAIGHT

| Code | Stand Size | Panels | Panel Size | Max | Packing | Total |
|----------|------------|--------|------------|-----|---------|-------|
| | Cm | Qty | Cm | Kg | Cm | Kg |
| BW184M01 | 26*15*50 | 1 | - | - | - | - |

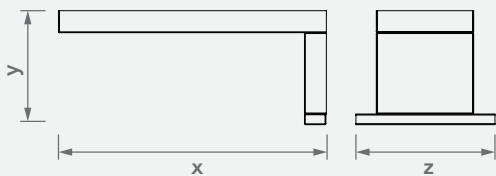

BW200S

| Code | Stand Size | Panels | Panel Size | Max | Packing | Total |
|----------|------------|--------|------------|-----|---------|-------|
| | Cm | Qty | Cm | Kg | Cm | Kg |
| BW200S01 | 40*10*42 | 1 | - | - | - | - |
| BW200S02 | 60*10*42 | 1 | - | - | - | - |
| BW200S03 | 80*10*42 | 1 | - | - | - | - |
| BW200S04 | 100*10*42 | 1 | - | - | - | - |

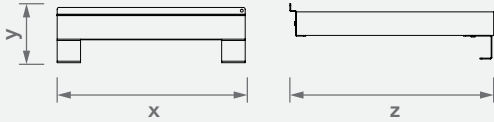

BW202S

| Code | Stand Size | Panels | Panel Size | Max | Packing | Total |
|----------|------------|--------|------------|-----|---------|-------|
| | Cm | Qty | Cm | Kg | Cm | Kg |
| BW202S01 | 40*10*42 | 1 | - | - | - | - |
| BW202S02 | 60*10*42 | 1 | - | - | - | - |
| BW202S03 | 80*10*42 | 1 | - | - | - | - |
| BW202S04 | 100*10*42 | 1 | - | - | - | - |

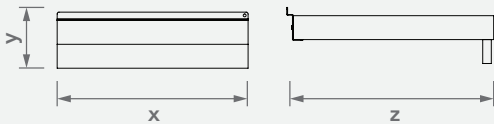

BW204S

| Code | Stand Size | Panels | Panel Size | Max | Packing | Total |
|----------|------------|--------|------------|-----|---------|-------|
| | Cm | Qty | Cm | Kg | Cm | Kg |
| BW204S01 | 40*10*42 | 6 | - | - | - | - |
| BW204S02 | 60*10*42 | 6 | - | - | - | - |
| BW204S03 | 80*10*42 | 6 | - | - | - | - |
| BW204S04 | 100*10*42 | 6 | - | - | - | - |

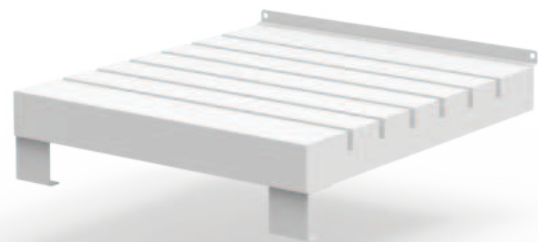
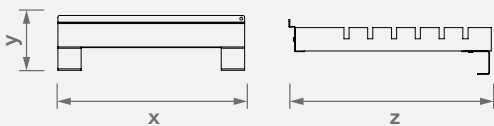

BW206S

| Code | Stand Size | Panels | Panel Size | Max | Packing | Total |
|----------|------------|--------|------------|-----|---------|-------|
| | Cm | Qty | Cm | Kg | Cm | Kg |
| BW206S01 | 40*10*42 | 6 | - | - | - | - |
| BW206S02 | 60*10*42 | 6 | - | - | - | - |
| BW206S03 | 80*10*42 | 6 | - | - | - | - |
| BW206S04 | 100*10*42 | 6 | - | - | - | - |

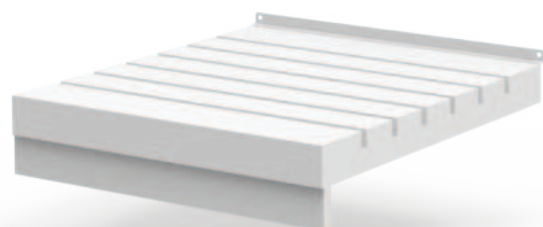
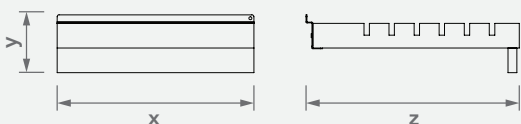

BW208S

| Code | Stand Size | Panels | Panel Size | Max | Packing | Total |
|----------|------------|--------|------------|-----|---------|-------|
| | Cm | Qty | Cm | Kg | Cm | Kg |
| BW208S01 | 40*10*62 | 1 | - | - | - | - |
| BW208S02 | 60*10*62 | 1 | - | - | - | - |
| BW208S03 | 80*10*62 | 1 | - | - | - | - |
| BW208S04 | 100*10*62 | 1 | - | - | - | - |

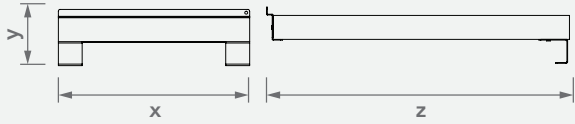

BW210S

| Code | Stand Size | Panels | Panel Size | Max | Packing | Total |
|----------|------------|--------|------------|-----|---------|-------|
| | Cm | Qty | Cm | Kg | Cm | Kg |
| BW210S01 | 40*10*62 | 1 | - | - | - | - |
| BW210S02 | 60*10*62 | 1 | - | - | - | - |
| BW210S03 | 80*10*62 | 1 | - | - | - | - |
| BW210S04 | 100*10*62 | 1 | - | - | - | - |

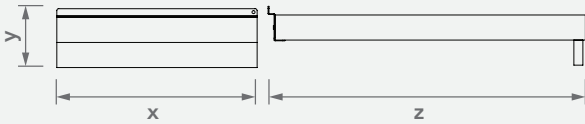

BW212S

| Code | Stand Size | Panels | Panel Size | Max | Packing | Total |
|----------|------------|--------|------------|-----|---------|-------|
| | Cm | Qty | Cm | Kg | Cm | Kg |
| BW212S01 | 40*10*62 | 6 | - | - | - | - |
| BW212S02 | 60*10*62 | 6 | - | - | - | - |
| BW212S03 | 80*10*62 | 6 | - | - | - | - |
| BW212S04 | 100*10*62 | 6 | - | - | - | - |

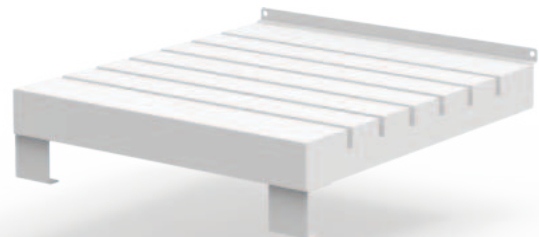
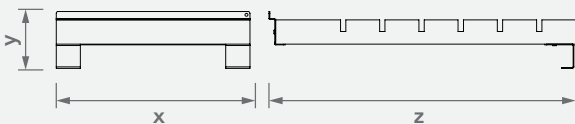

BW214S

| Code | Stand Size | Panels | Panel Size | Max | Packing | Total |
|----------|------------|--------|------------|-----|---------|-------|
| | Cm | Qty | Cm | Kg | Cm | Kg |
| BW214S01 | 40*10*62 | 6 | - | - | - | - |
| BW214S02 | 60*10*62 | 6 | - | - | - | - |
| BW214S03 | 80*10*62 | 6 | - | - | - | - |
| BW214S04 | 100*10*62 | 6 | - | - | - | - |

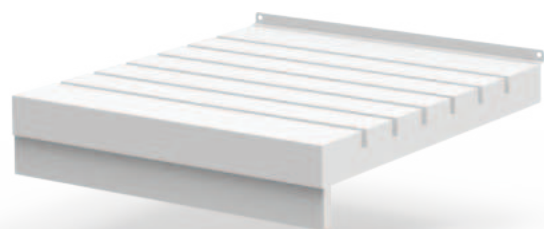
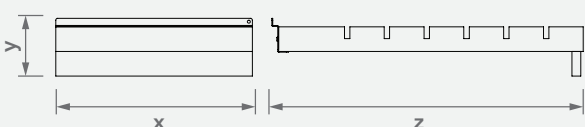

BW216S

| Code | Stand Size | Panels | Panel Size | Max | Packing | Total |
|----------|------------|--------|------------|-----|---------|-------|
| | Cm | Qty | Cm | Kg | Cm | Kg |
| BW216S01 | 40*10*42 | 6 | - | - | - | - |
| BW216S02 | 60*10*42 | 6 | - | - | - | - |
| BW216S03 | 80*10*42 | 6 | - | - | - | - |
| BW216S04 | 100*10*42 | 6 | - | - | - | - |

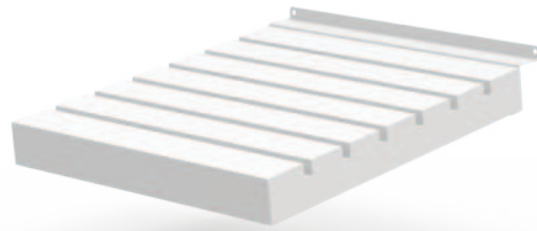
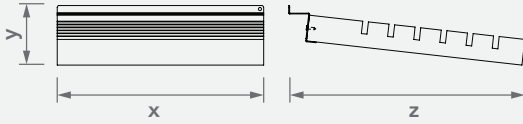

BW218S

| Code | Stand Size | Panels | Panel Size | Max | Packing | Total |
|----------|------------|--------|------------|-----|---------|-------|
| | Cm | Qty | Cm | Kg | Cm | Kg |
| BW218S01 | 40*10*62 | 10 | - | - | - | - |
| BW218S02 | 60*10*62 | 10 | - | - | - | - |
| BW218S03 | 80*10*62 | 10 | - | - | - | - |
| BW218S04 | 100*10*62 | 10 | - | - | - | - |

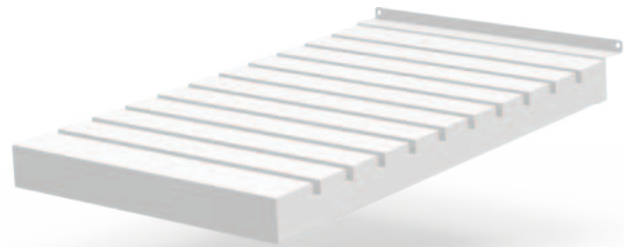
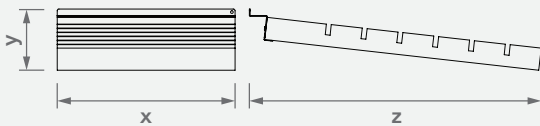

BW300S

UNIT / COVERED

| Code | Stand Size | Panels | Panel Size | Max | Packing | Total |
|----------|------------|--------|------------|-----|---------|-------|
| | Cm | Qty | Cm | Kg | Cm | Kg |
| BW300S01 | 40*85*44 | - | - | - | - | - |
| BW300S02 | 60*85*44 | - | - | - | - | - |
| BW300S03 | 80*85*44 | - | - | - | - | - |
| BW300S04 | 100*85*44 | - | - | - | - | - |

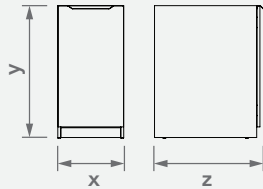

BW302S

UNIT / DRAWER

| Code | Stand Size | Panels | Panel Size | Max | Packing | Total |
|----------|------------|--------|------------|-----|---------|-------|
| | Cm | Qty | Cm | Kg | Cm | Kg |
| BW302S02 | 60*85*44 | - | - | - | - | - |
| BW302S03 | 80*85*44 | - | - | - | - | - |
| BW302S04 | 100*85*44 | - | - | - | - | - |

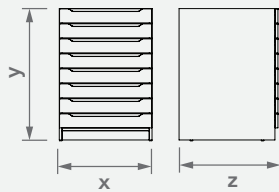

BW304S

UNIT / DRAWER / WITH SLOTS

| Code | Stand Size | Panels | Panel Size | Max | Packing | Total |
|----------|------------|--------|------------|-----|---------|-------|
| | Cm | Qty | Cm | Kg | Cm | Kg |
| BW304S03 | 80*85*44 | - | - | - | - | - |
| BW304S04 | 100*85*44 | - | - | - | - | - |

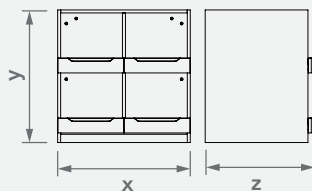

BW306S

UNIT / DRAWER / WITH FIXED

| Code | Stand Size | Panels | Panel Size | Max | Packing | Total |
|----------|------------|--------|------------|-----|---------|-------|
| | Cm | Qty | Cm | Kg | Cm | Kg |
| BW306S03 | 80*85*44 | - | - | - | - | - |
| BW306S04 | 80*85*44 | - | - | - | - | - |

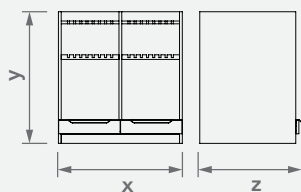

BW308S

UNIT / COVERED

| Code | Stand Size | Panels | Panel Size | Max | Packing | Total |
|----------|------------|--------|------------|-----|---------|-------|
| | Cm | Qty | Cm | Kg | Cm | Kg |
| BW308S01 | 40*85*64 | - | - | - | - | - |
| BW308S02 | 60*85*64 | - | - | - | - | - |
| BW308S03 | 80*85*64 | - | - | - | - | - |
| BW308S04 | 100*85*64 | - | - | - | - | - |

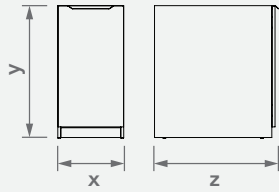

BW310S

UNIT / DRAWER

| Code | Stand Size | Panels | Panel Size | Max | Packing | Total |
|----------|------------|--------|------------|-----|---------|-------|
| | Cm | Qty | Cm | Kg | Cm | Kg |
| BW310S02 | 60*85*64 | - | - | - | - | - |
| BW310S03 | 80*85*64 | - | - | - | - | - |
| BW310S04 | 100*85*64 | - | - | - | - | - |

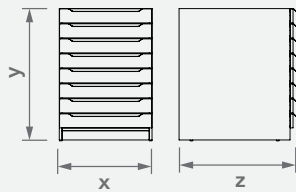

BW312S

UNIT / DRAWER / WITH SLOTS

| Code | Stand Size | Panels | Panel Size | Max | Packing | Total |
|----------|------------|--------|------------|-----|---------|-------|
| | Cm | Qty | Cm | Kg | Cm | Kg |
| BW312S03 | 80*85*64 | - | - | - | - | - |
| BW312S04 | 100*85*64 | - | - | - | - | - |

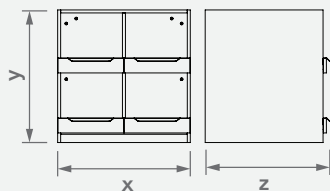

BW314S

UNIT / DRAWER / WITH FIXED

| Code | Stand Size | Panels | Panel Size | Max | Packing | Total |
|----------|------------|--------|------------|-----|---------|-------|
| | Cm | Qty | Cm | Kg | Cm | Kg |
| BW314S03 | 80*85*64 | - | - | - | - | - |
| BW314S04 | 80*85*64 | - | - | - | - | - |

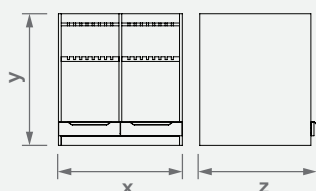

BW316S

UNIT / WITH SHELF

| Code | Stand Size | Panels | Panel Size | Max | Packing | Total |
|----------|------------|--------|------------|-----|---------|-------|
| | Cm | Qty | Cm | Kg | Cm | Kg |
| BW316S03 | 80*85*42 | - | - | - | - | - |
| BW316S04 | 100*85*42 | - | - | - | - | - |

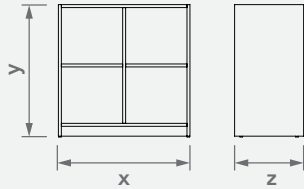

BW318S

UNIT / DRAWER WITH SLOTS

| Code | Stand Size | Panels | Panel Size | Max | Packing | Total |
|----------|------------|--------|------------|-----|---------|-------|
| | Cm | Qty | Cm | Kg | Cm | Kg |
| BW318S03 | 80*85*44 | - | - | - | - | - |
| BW318S04 | 100*85*44 | - | - | - | - | - |

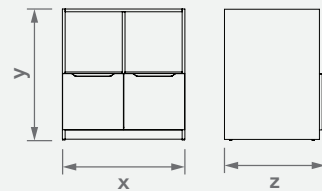

BW320S

UNIT / UPPER TABLE

| Code | Stand Size | Panels | Panel Size | Max | Packing | Total |
|----------|------------|--------|------------|-----|---------|-------|
| | Cm | Qty | Cm | Kg | Cm | Kg |
| BW320S01 | 40*2*44 | - | - | - | - | - |
| BW320S02 | 60*2*44 | - | - | - | - | - |
| BW320S03 | 80*2*44 | - | - | - | - | - |
| BW320S04 | 100*2*44 | - | - | - | - | - |



BW322S

UNIT / UPPER TABLE WITH EVA

| Code | Stand Size | Panels | Panel Size | Max | Packing | Total |
|----------|------------|--------|------------|-----|---------|-------|
| | Cm | Qty | Cm | Kg | Cm | Kg |
| BW322S01 | 40*2*44 | - | - | - | - | - |
| BW322S02 | 60*2*44 | - | - | - | - | - |
| BW322S03 | 80*2*44 | - | - | - | - | - |
| BW322S04 | 100*2*44 | - | - | - | - | - |



BW324S

UNIT / WITH SHELF

| Code | Stand Size | Panels | Panel Size | Max | Packing | Total |
|----------|------------|--------|------------|-----|---------|-------|
| | Cm | Qty | Cm | Kg | Cm | Kg |
| BW324S03 | 80*85*64 | 14 | - | - | - | - |
| BW324S04 | 100*85*64 | 14 | - | - | - | - |

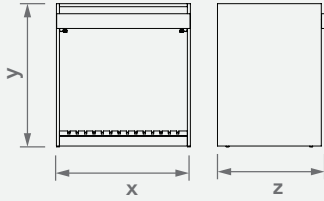

BW326S

UNIT / DRAWER

| Code | Stand Size | Panels | Panel Size | Max | Packing | Total |
|----------|------------|--------|------------|-----|---------|-------|
| | Cm | Qty | Cm | Kg | Cm | Kg |
| BW326S03 | 80*85*64 | - | - | - | - | - |
| BW326S04 | 100*85*64 | - | - | - | - | - |

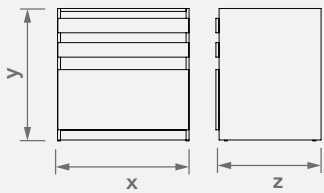

BW328S

UNIT / UPPER TABLE

| Code | Stand Size | Panels | Panel Size | Max | Packing | Total |
|----------|------------|--------|------------|-----|---------|-------|
| | Cm | Qty | Cm | Kg | Cm | Kg |
| BW328S01 | 40*2*64.2 | - | - | - | - | - |
| BW328S02 | 60*2*64.2 | - | - | - | - | - |
| BW328S03 | 80*2*64.2 | - | - | - | - | - |
| BW328S04 | 100*2*64.2 | - | - | - | - | - |



BW330S

UNIT / UPPER TABLE WITH EVA

| Code | Stand Size | Panels | Panel Size | Max | Packing | Total |
|----------|------------|--------|------------|-----|---------|-------|
| | Cm | Qty | Cm | Kg | Cm | Kg |
| BW330S01 | 40*2*64.2 | - | - | - | - | - |
| BW330S02 | 60*2*64.2 | - | - | - | - | - |
| BW330S03 | 80*2*64.2 | - | - | - | - | - |
| BW330S04 | 100*2*64.2 | - | - | - | - | - |



MATRIX VARIATION

BMW, BMW

VARIATION

BW Series
BM Series

VARIATION
VARIATION

Panel Variations

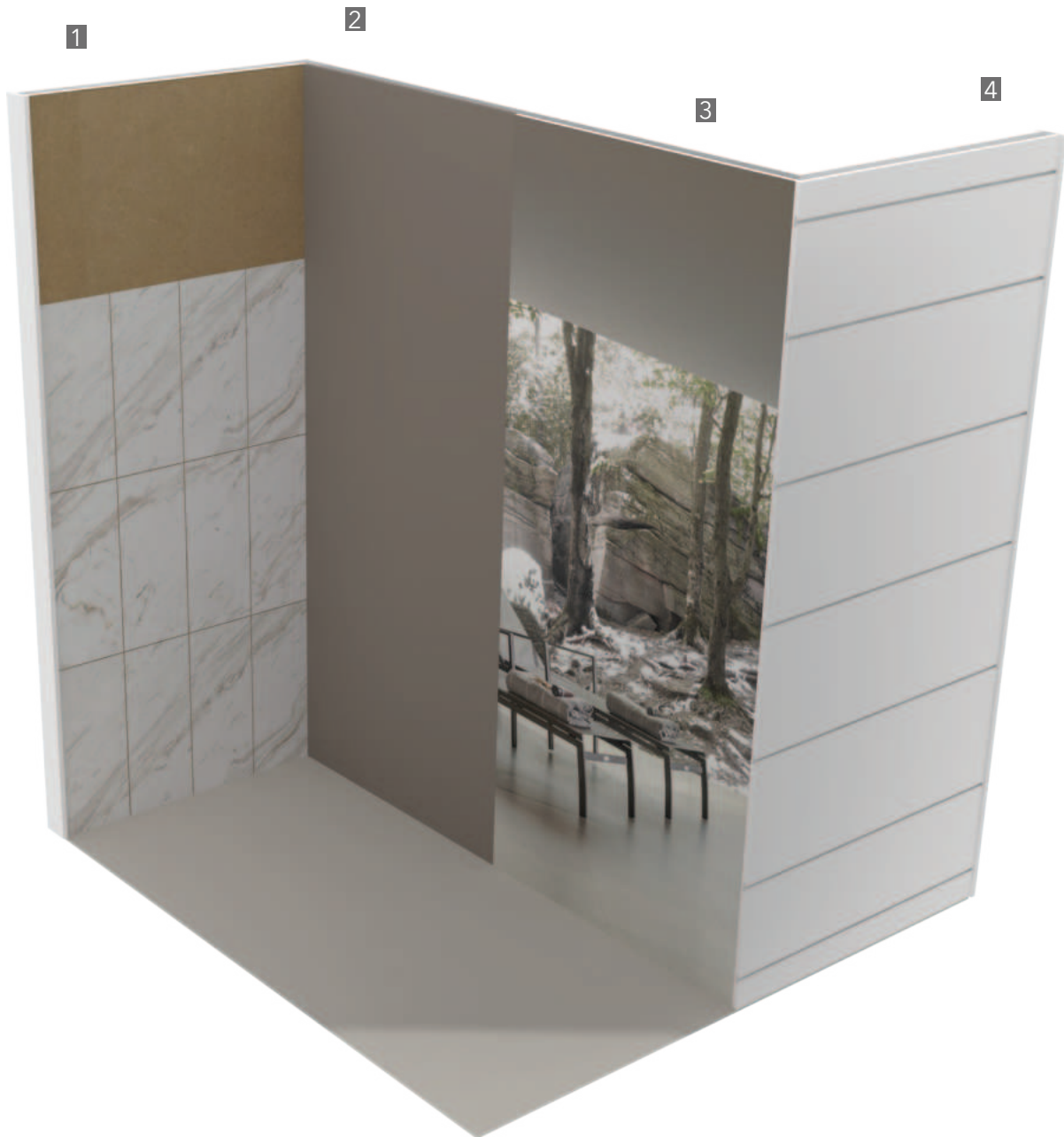

- 1 Mdf
- 2 Lacquered
- 3 Printing
- 4 Technical Wall

Frames assembly

1



- 1 inner pole
- 2 inner pole
- 3 iron frame

Assembly of the inner support for furnitures

2



- 4 strengthening part

3

Assembly of mdf panels (for tiles, or photos or paint ...)

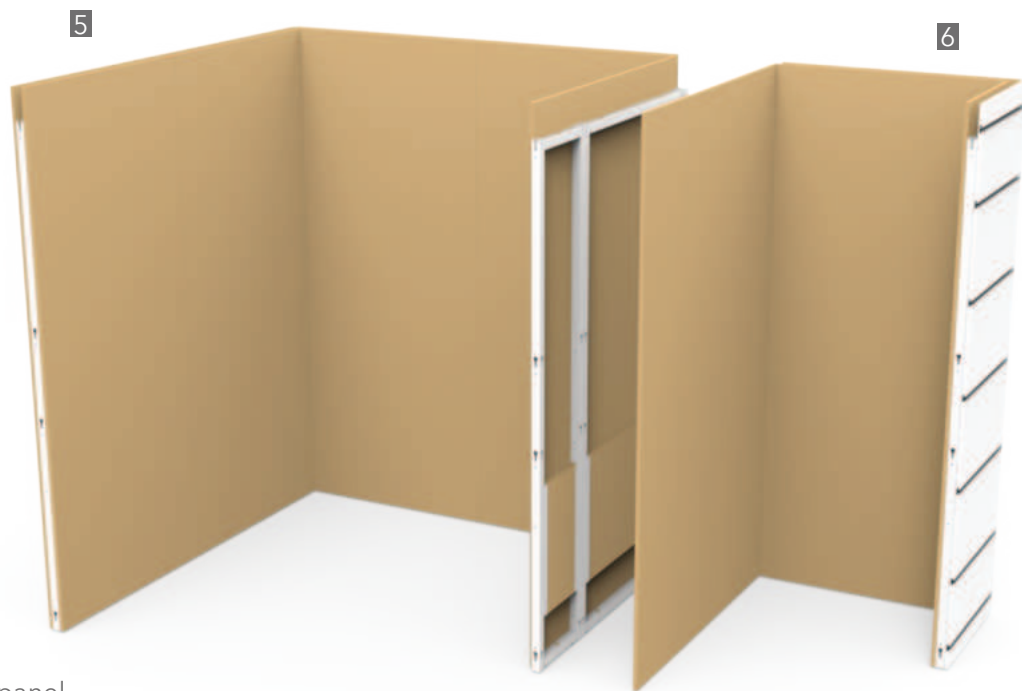

5 mdf panel
6 technical wall

4

Tiling, Painting or Ready Made Stand

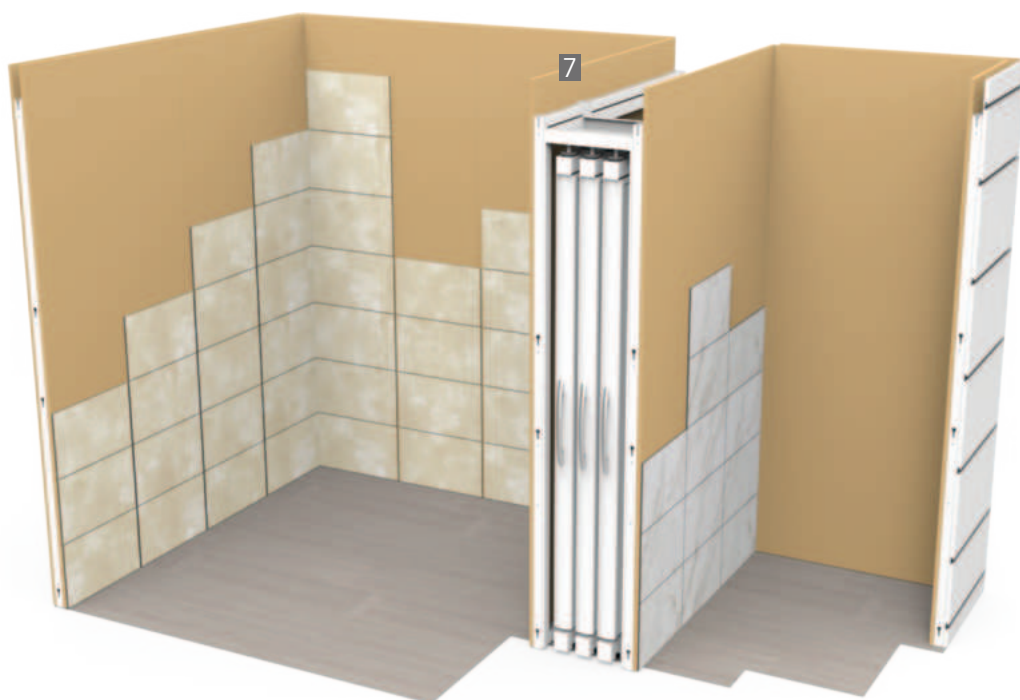

7 BR1

Assembly of the closing elements

5



8 closing element

Matrix System- Your Setting box is ready!

6



L

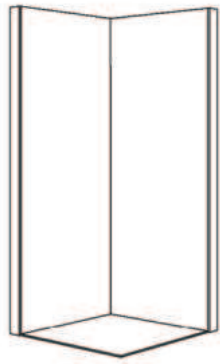

Example of L combination

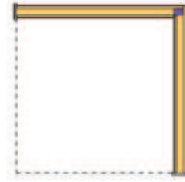

T

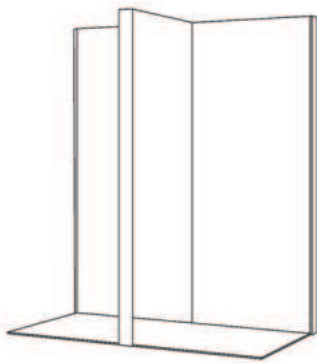

Example of T combination

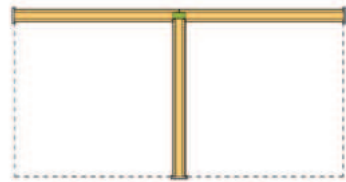

Z

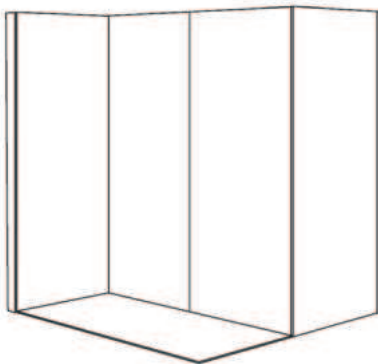

Example of Z combination

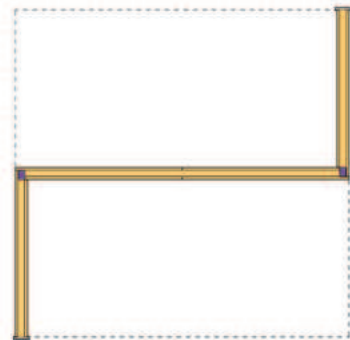

X

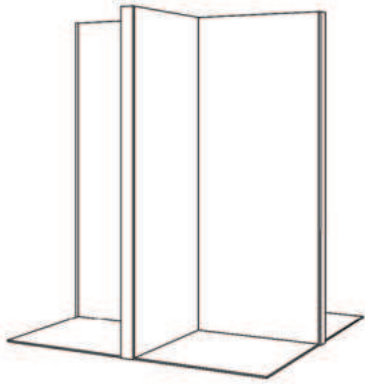

Example of X combination

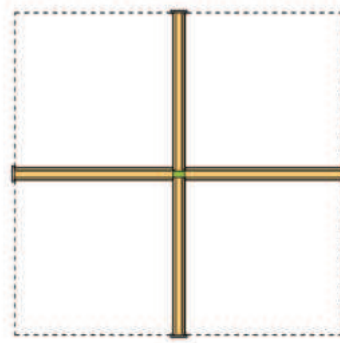

Y

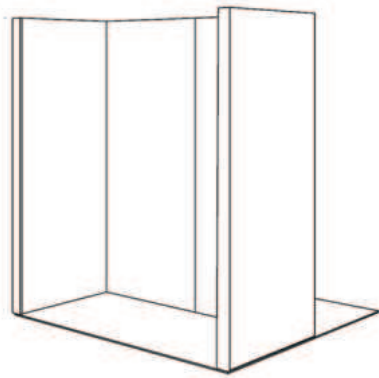

Example of Y combination

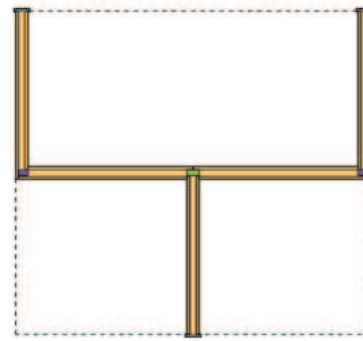

H

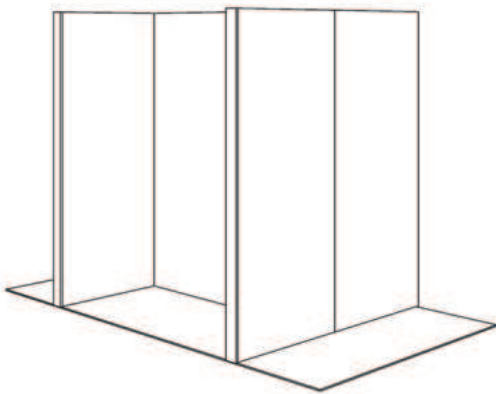

Example of H combination

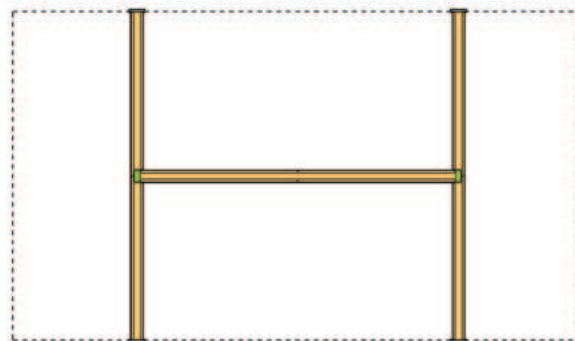

MATRIX

Example of ready boxes

example01

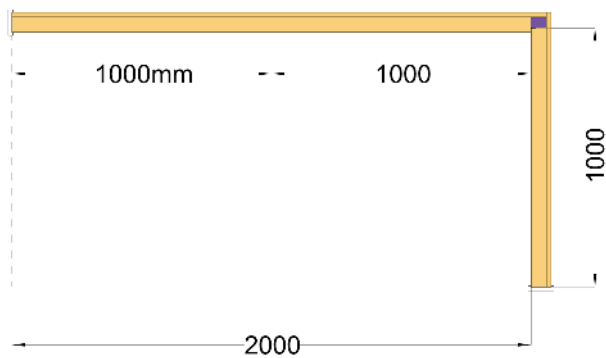

MATRIX

Example of ready boxes

example02

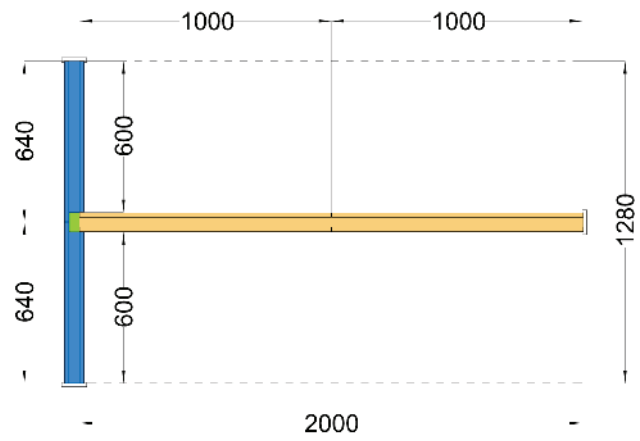

MATRIX

Example of ready boxes

example03

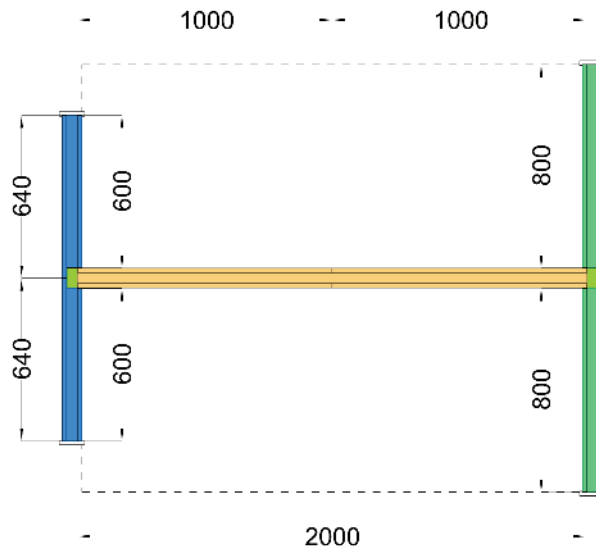

MATRIX

Example of ready boxes

example04

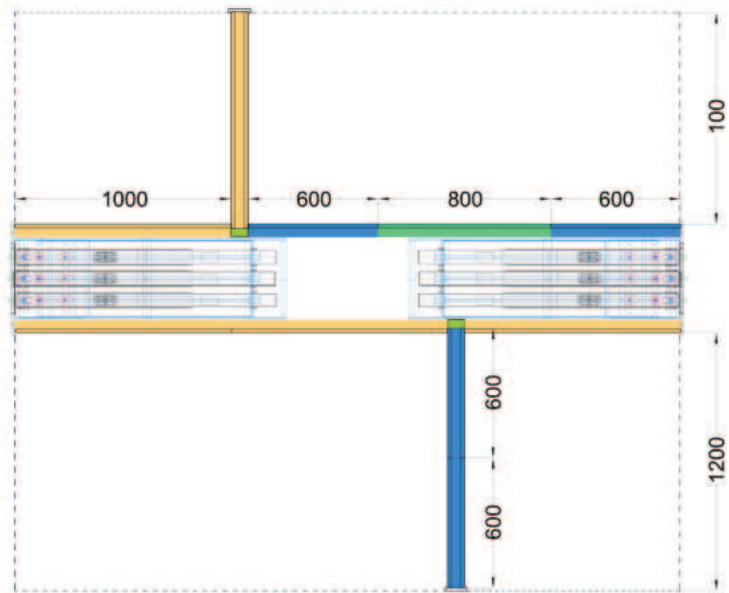

MATRIX

Example of ready boxes
example09

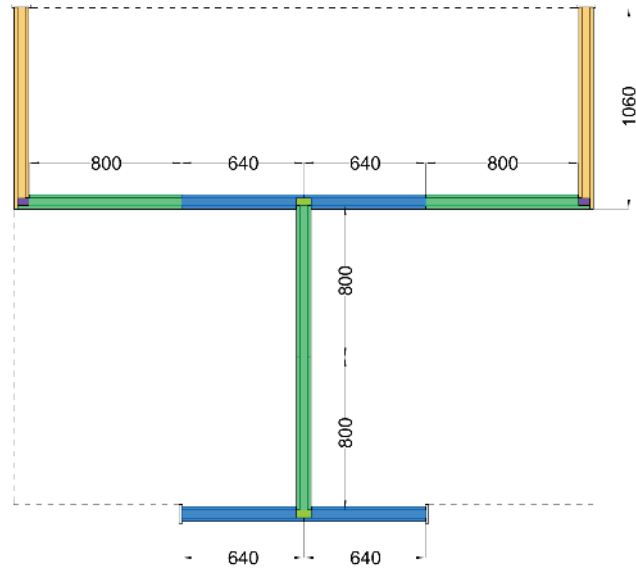

MATRIX

Example of ready boxes
example10

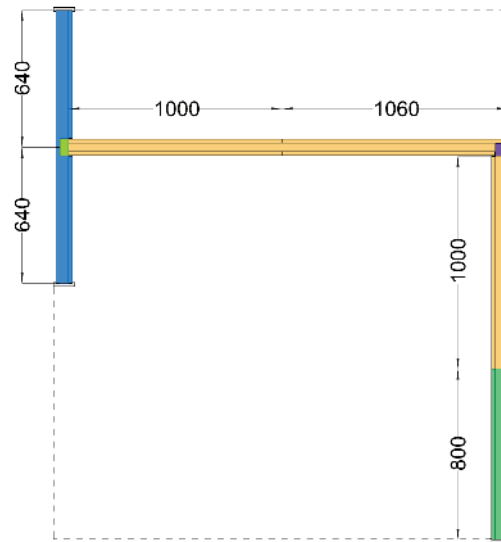

MATRIX

Example of show-room fitting-out

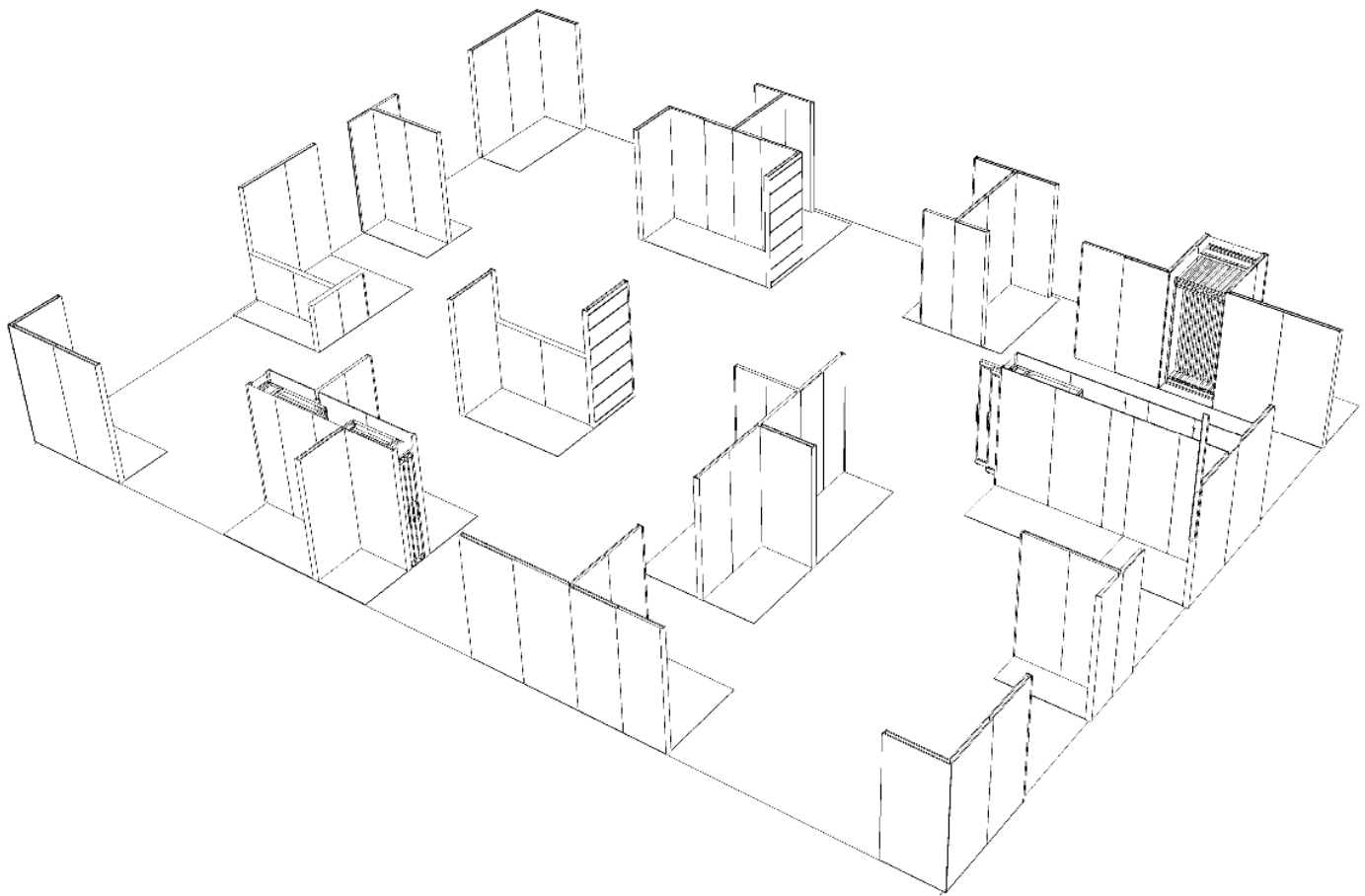
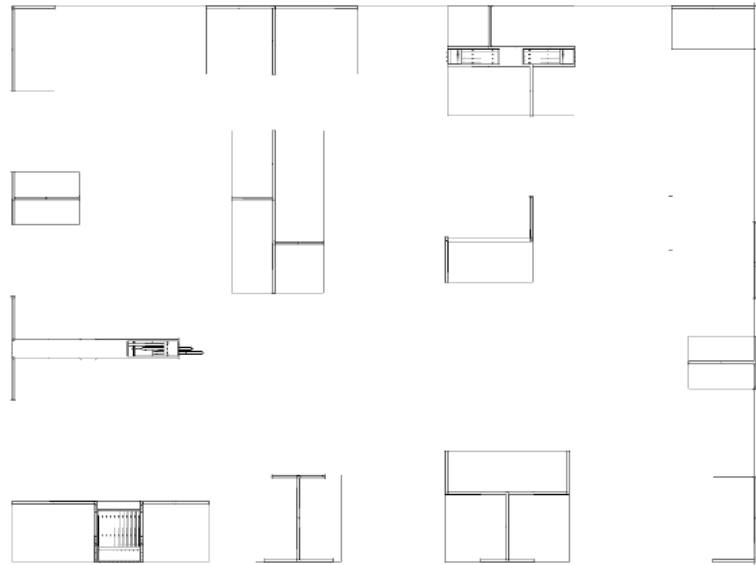

MATRIX

Example of show-room fitting-out

Self standing element



MATRIX

Example of show-room fitting-out
Self standing element



MATRIX

Example of show-room fitting-out

Self standing element



TECHNICAL WALL

BRT1

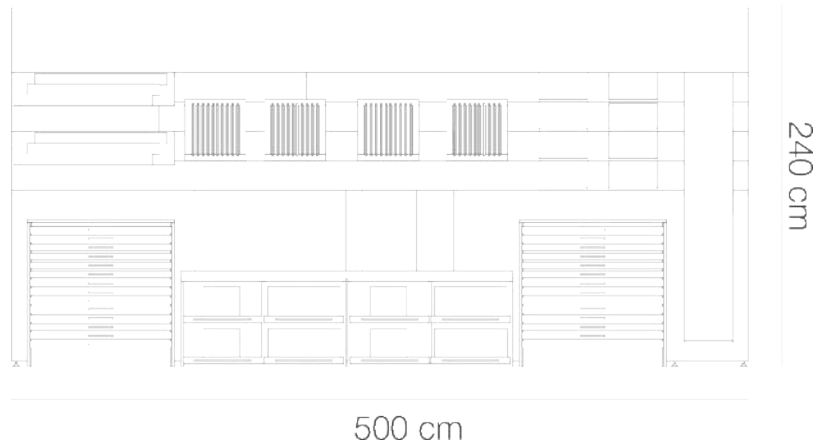

TECHNICAL WALL

BRT2

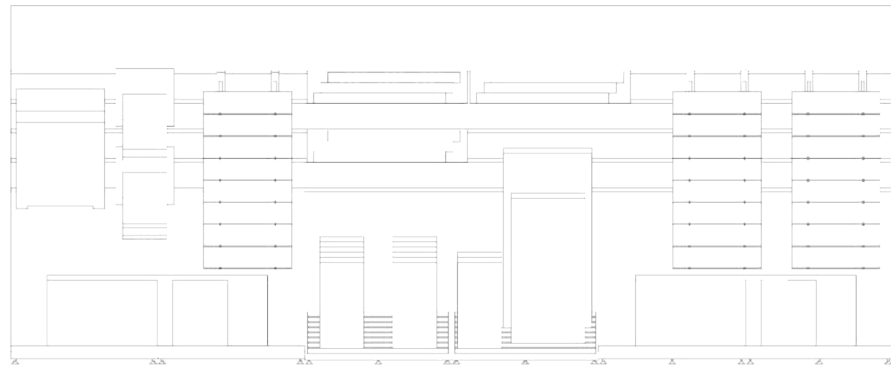

240 cm

600 cm



TECHNICAL WALL

BRT3

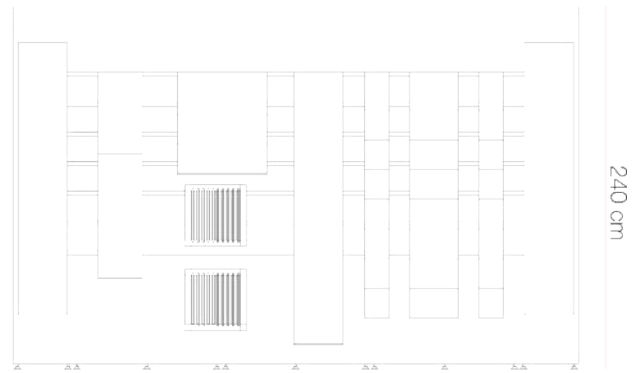

380 cm

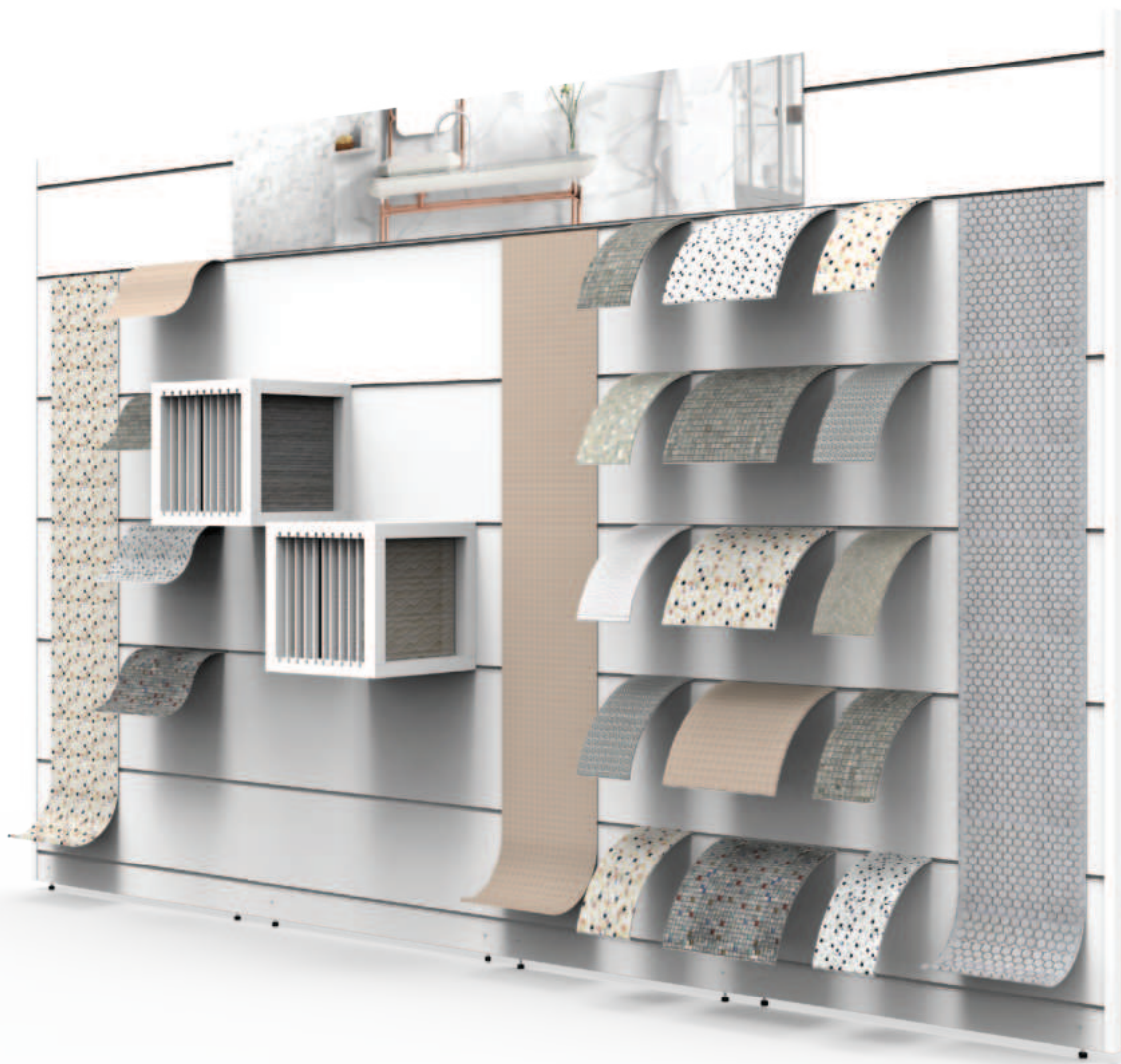

TECHNICAL WALL

BRT4

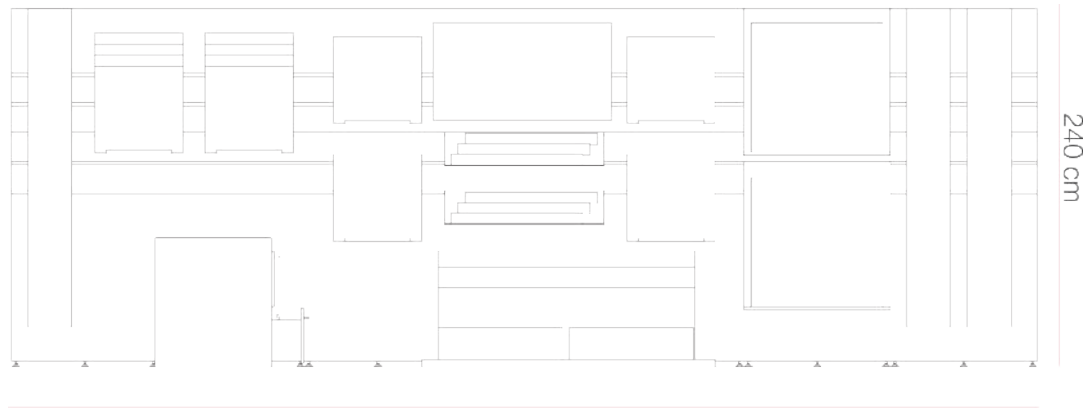

700 cm

240 cm



COLORS

BMW, BMW

COLOUR

BW Series
BM Series

COLOUR CHART COLOUR

COLOUR CHART

LACQUER MDF COLOUR



L 9016 M
BrLac White Matt



L 9016 G
BrLac White Glossy



L 9005 M
BrLac Black Matt



L 9005 G
BrLac Black Glossy



L 9001 M
BrLac Beige Matt

LACQUER MDF COLOUR



L 9618 M
BrLac Bronze Matt



L 9006 M
BrLac Grey Matt

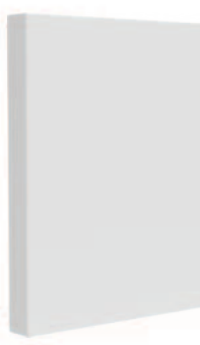

L 9006 G
BrLac Grey Glossy



L 7043 M
BrLac Ash Grey Matt



L 3434 M
BrLac Antracite Matt

LACQUER MDF COLOUR



L 9007 M
BrLac Dark Grey Matt



L 4848 S
BrLac Antracite Sym

ACCESSORY ALU, PLSTC, GLASS COLOUR



A 9016 M
Br White Matt



A 9005 M
Br Black Matt

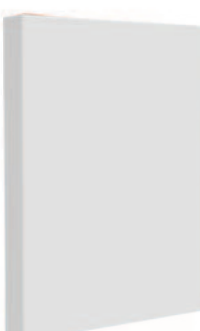

A 9006 M
Br Grey Matt



A 0801 G
Br Naturel Glass



A 0802 G
Br Satine Glass

COLOUR CHART

METAL COLOUR



M 9016 M
Br White Matt RAL



M 9016 G
Br White Glossy RAL



M 9016 T
Br White Texture RAL



M 9016 O
Br White Org. Texture RAL



M 9001 M
Br Beige Matt RAL

METAL COLOUR



M 9005 M
Br Black Matt RAL



M 9005 G
Br Black Glossy RAL



M 9005 T
Br Black Texture RAL



M 9005 O
Br Black Org. Texture RAL



M 9618
Br Bronze Matt

METAL COLOUR



M 9006 M
Br Grey Matt RAL



M 9006 G
Br Grey Glossy RAL



M 9006 T
Br Grey Texture RAL

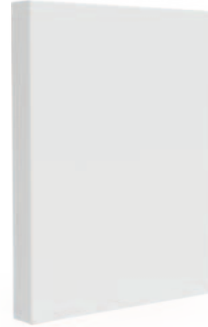

M 9006 H
Br Grey H Glossy RAL

METAL COLOUR

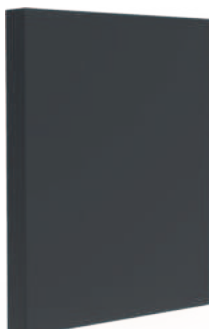

M 7043 M
Br Ash Grey Matt



M 3434 M
Br Antracite Matt



M 4848 S
Br Antracite Sym Texture



M 9007 M
Br Dark Grey Matt RAL

COLOUR CHART

LAMINATED MDF, CHIPBOARD COLOUR



W 9016 M
BrLam White Matt



W 9016 G
BrLam White Semi Matt



W 9005 M
BrLam Black Matt



W 9005 G
BrLam Black Semi Matt



W 9001 M
BrLam Beige Matt

LAMINATED MDF, CHIPBOARD COLOUR



W 9007 M
BrLam Dark Grey Matt



W 9006 M
BrLam Grey Matt



W 3434 M
BrLam Antracite Matt



W 7043 M
BrLam Ash Grey Matt

LIGHT COLOUR

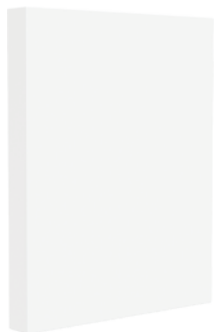

A 0950 G
Br Day Light 6500K

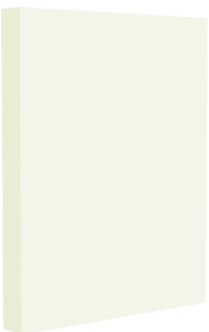

A 0951 G
Br Bright Light 4100K



A 0952 G
Br Warm Light 3000K

!..Bora Çelik reserves the right to change the size and technical details of the products. Please check with your order against the possibility of measure, code, and colour errors in the catalogue. Due to the print quality, colours of product may vary.

boracelik



TÜRKİYE

Organize Sanayi Bölgesi 21. Cadde No:41
Pk:26250 Eskişehir / Türkiye
T +90 222 236 19 40 **F** +90 222 236 19 41
E info@boracelik.com.tr

ITALY

Boracelik Italy S.r.l. Via del Crociale. 30. 41042
Spezzano di Fiorano Modenese (MO) Italy
T +39 0536 920519
E acorradi@boracelik.it

SPAIN

Avda Mediterraneo N120. Nave 3.12200
Onda (Castellon) Spain
T +34 626 965 787 / +34 964 626 260
E boracelikespana@boracelik.es

boracelik

ESKİŐEHİR TURKEY
CASTELLON SPAIN
SASSUOLO ITALY

MATRIX 2134 CATALOG