

boracelik

ALL IN ONE
DISPLAY
SOLUTIONS

EPSON
CATALOG
ONLINE

boracelik

ALL IN ONE
DISPLAY SOLUTIONS

EPSILON CATALOG

boracelik

ALL IN ONE
DISPLAY SOLUTIONS

EPSILON CATALOG

About Us Founded in 1976, Bora Çelik is a made-to-order designer, manufacturer supplier of showroom display panels, situated in Eskisehir, Turkey. Our main product lines consist of, but are not limited to, ceramic display cabinets, display panels, door displays, tile display stands, along with parquet, tile, stone, marble, mosaic displays. We also design and manufacture commercial areas and showrooms that cater to the ceramics and bathroom industries. Our strength comes from our custom design and unique production capabilities, ensuring that both our production and supply organizations are flexible enough to manufacture and deliver any volumes, in short, we can and will deliver any amount of product within the timescale required, without any order restrictions, with branding and packing being decided by our clients. Our highly skilled design team will ensure that all aspects of quality, dimensions, and general design-build meet your expectations, whilst providing a tailored and cost-effective solution to your needs, when productivity is essential. Bora Çelik is here for you, as a trustworthy supplier when you require comprehension, communication, research, and service.

Epsilon Series consist of two main elements as skeleton frames and drawers that can be adapted to many different areas and sizes of products to be displayed. It is designed for the effective use of the area preserving the design integrity of the fair and showroom areas. Epsilon series which is designed with the aim of producing a more organic and modern presentation, exhibition areas provide effective use of space by preserving architectural design integrity. Epsilon Series, which enables the presentation of a wide range of products such as ceramic, tile, stone, book and shelf products in square and rectangular form. It is produced as completely disassembled without the need for a different material and can be easily installed. Epsilon, which also aims to present large-scale products in an aesthetic way, is produced from two main durable materials as wood and metal.



Bora Çelik, which is renewing and developing itself day by day with the products it produces on a national and international scale and global projects, became the owner of the title of "Design Center" by receiving the incentive support of the Ministry of Science, Industry, and Technology to bring the country's economy to an internationally competitive structure.

Epsilon consists of 3 main groups as; Gama A consisting of tables, chairs and drawers, Gama B consisting of metal frame, which is a group product and used for placemaking, Gama C that allows the presentation of armature products.

Who are we Bora Çelik's key success comes from its dynamic, innovative, entrepreneur structure and harmony energy in its own up to now and so it has been. Our company has an 18.000 m² closed area in Eskisehir. Bora Çelik architectural retail design concentrates on exhibition design as converted developed notions for retail strategy into different space type segmentation and architectural structure by creating concept designs.

What we are doing
Design (corporate identity - store - exhibition, etc.) Performance (store concept turn-key/ domestic- foreign) Production (mass production of showroom equipment/custom design production) Frontal design and application (siding/advertising board application etc.) exhibition design + application (domestic foreign)



DESIGN

Epsilon series consists of two main elements as shelves frames and drawers that can be adapted to many different areas and sizes of products to be displayed. It is designed for the effective use of the area preserving the design integrity of the furniture elements series.

Epsilon series which is designed with the aim of producing a more organic and modern presentation, exhibition areas provide effective use of space by preserving architectural design integrity. Epsilon Series, which reaches the presentation of a wide range of products such as ceramic, tile, stone, brick and shell products in square and octagonal forms. It is produced as completely disassembled without the need for additional material and can be easily installed.



GAMA-A

Consisting of a well-equipped table, chair and drawer, Gama A system aims to expose products

Can be painted in different colors
Custom made display units according to the location

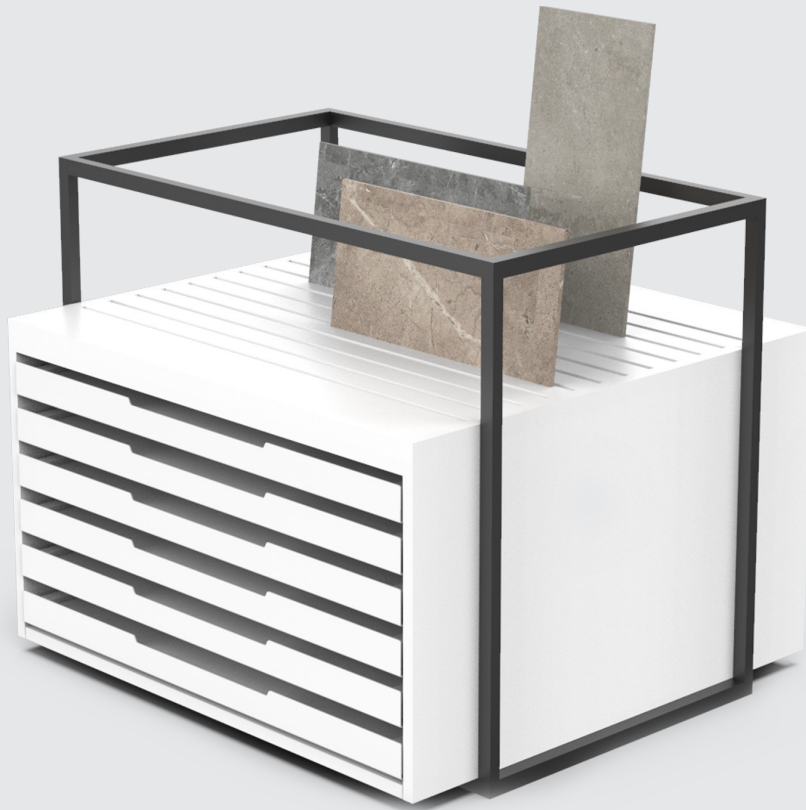
**BE001V01****TOTEM**

- 146x97x130 cm frame
- 120x120 cm drawer,
- 6 horizontal frame, 70 kg
- Cradle on top 30*60 cm 12 panels

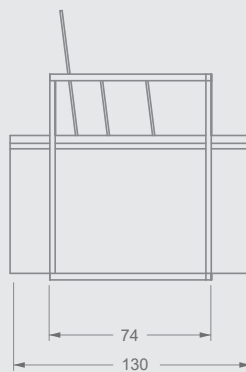
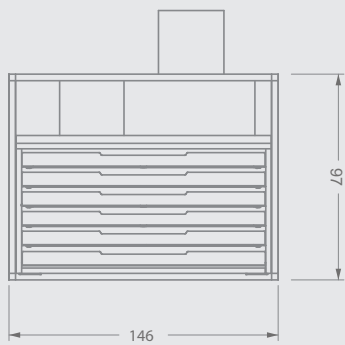

**BE001V02**

TABLE

- 240x99x130 cm frame
- 120x120 cm drawer
- 9 horizontal frame, 70 kg
- Table top adjustable LAM,LACQUER,GLASS,EVA

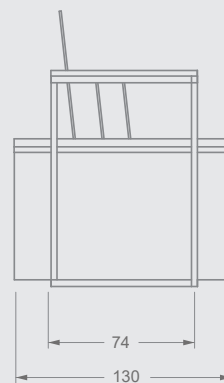
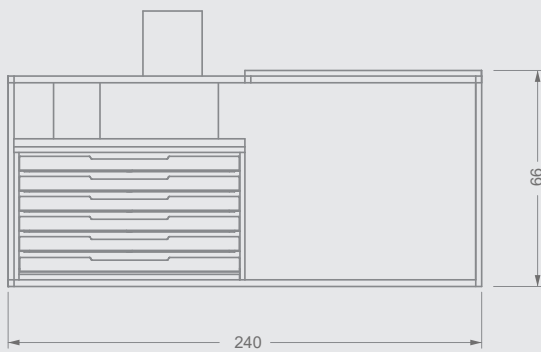

**BE001V03**

TABLE

- 240x99x130 cm frame
- 120x120 cm drawer,
- 6 horizontal frame,
- 70 kg with cradle on top 30*60 cm 12 panels
- Table top adjustable LAM,LACQUER,GLASS,EVA

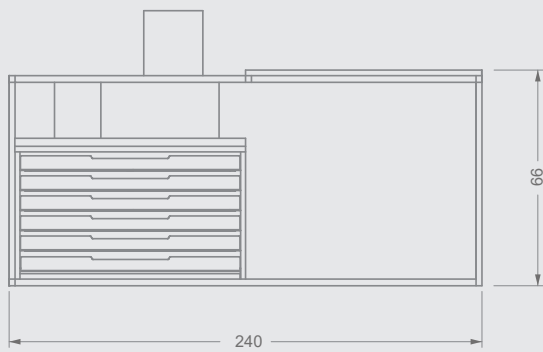

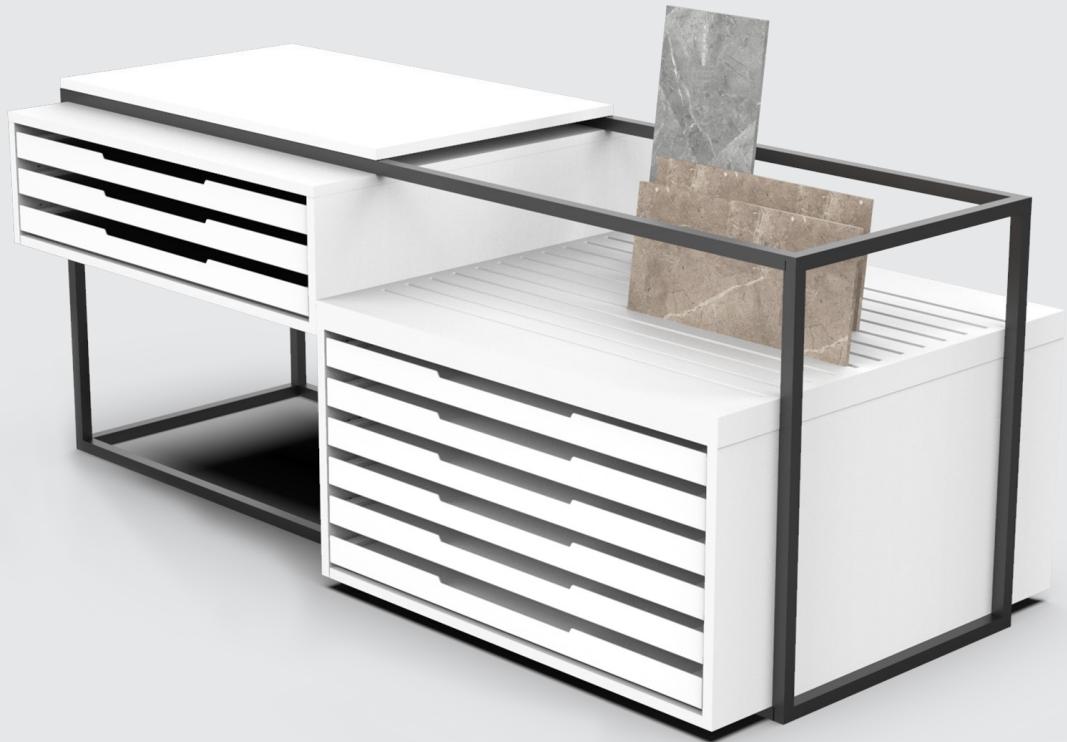
**BE001V04**

TABLE

- 281x99x130 cm frame
- 120x120 cm drawer,
- 6 horizontal, 3 horizontal frame
- 70 kg with cradle on top 30*60 cm 12 panels
- Table top adjustable LAM, LACQUER, GLASS, EVA

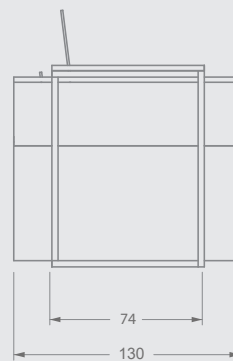
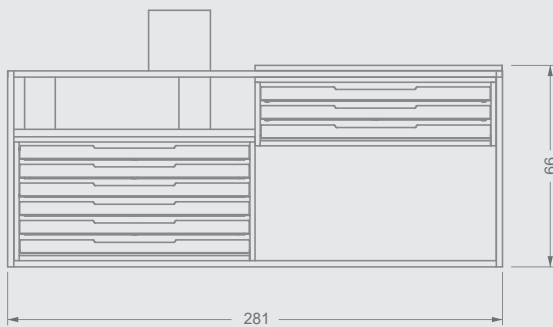

**BE001V05**

TABLE

- 355x99x130 cm frame
- 120x120 cm drawer,
- 9+9 horizontal frame,70 kg
- Table top adjustable LAM,LACQUER,GLASS,EVA

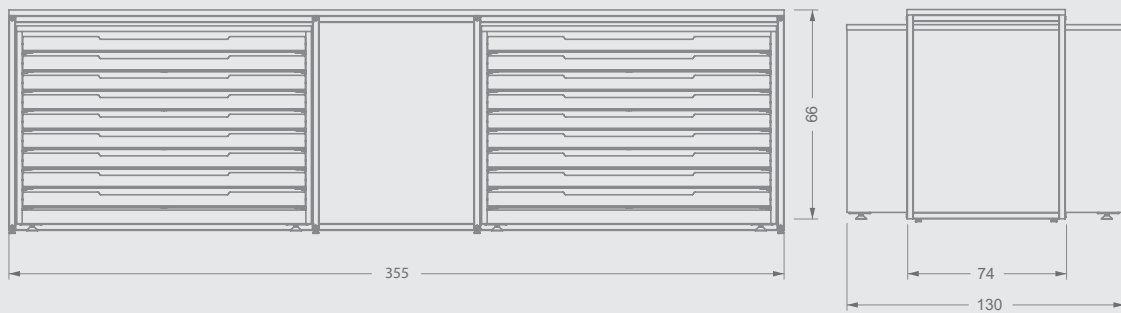

**BE010V06**

STOOL

- 37x67,5x37 cm frame stool

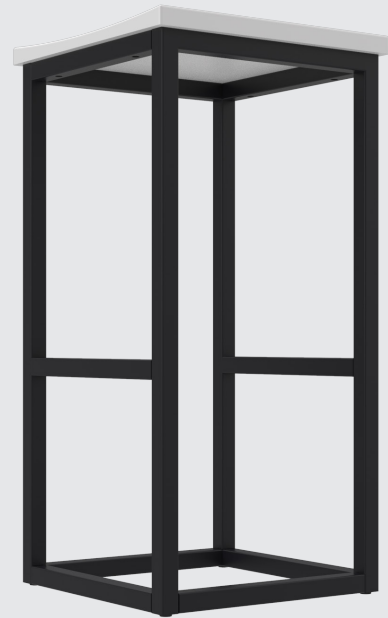
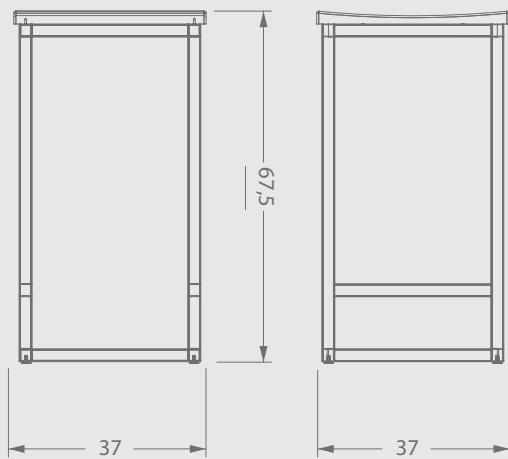
**BE010V07**

STOOL

- 37x75x37 cm frame stool

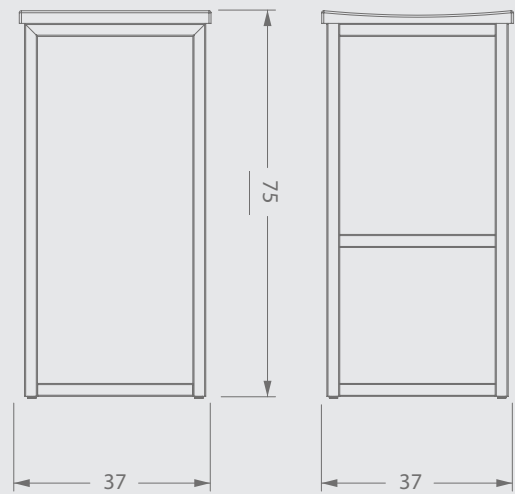





GAMA-B

Designed to create a living space within the exhibition area and to display large-scale group products such as bathtubs and shower cabinets.

Can be painted in different colors
Custom made display units according to the location

**BE002V71****STAND**

- 141x280x71 cm frame
- 60x120 cm drawer, 6 panels 70 kg
- MDFLAM technical wall with channel
- 35x35 cm mosaic hanger 20 pcs

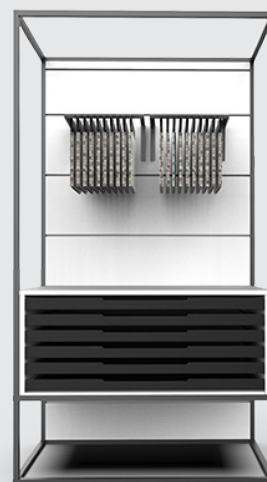
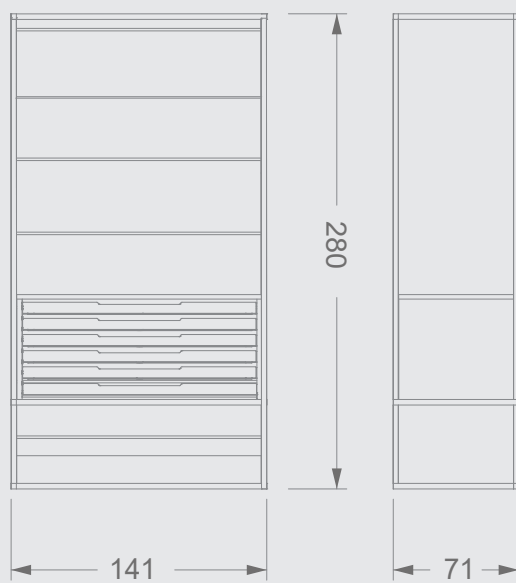

**BE002V72****STAND**

- 247x280x71 cm frame
- 60x120 cm drawer, 6 panels 70 kg
- 10x2 panels 60x120 cm pulling
- MDFLAM shelf
- Raw chipboard wall
- 65x65 cm front panel(digital print, tile glue,)

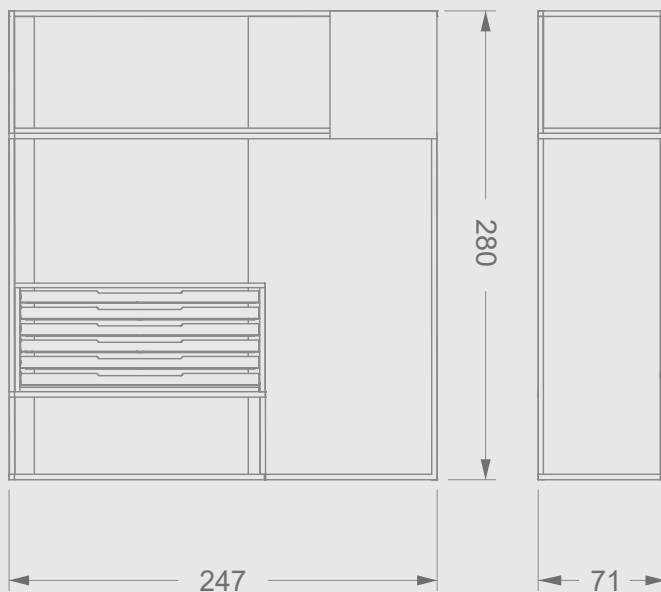

**BE002V73****STAND**

- 240x280x79 cm frame
- 60x120 cm drawer, 18 panels
- 60*60 cm cradles 10 panels
- MDFLAM technical wall with channel
- 35x35 cm mosaic hanger 20 pcs
- Adjustable shelf for small pieces

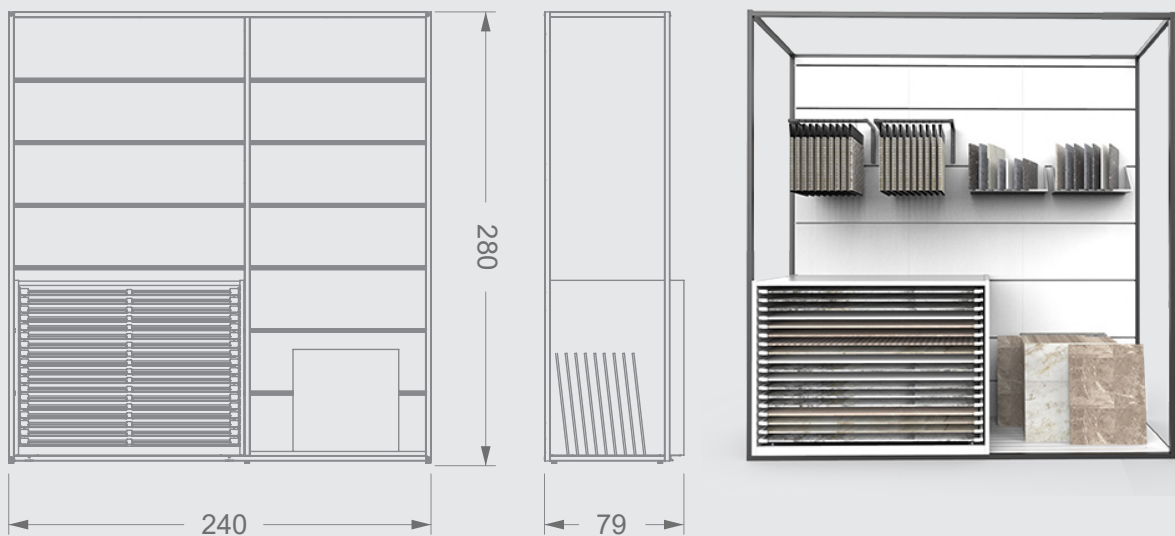

**BE002V74****STAND**

- 240x280x130 cm frame
- 120x120 cm drawer
- Cradle on top 30*60 cm 10 panels
- 60*60 cm cradles 10 panels
- MDFLAM technical wall with channel
- Adjustable shelf for small pieces

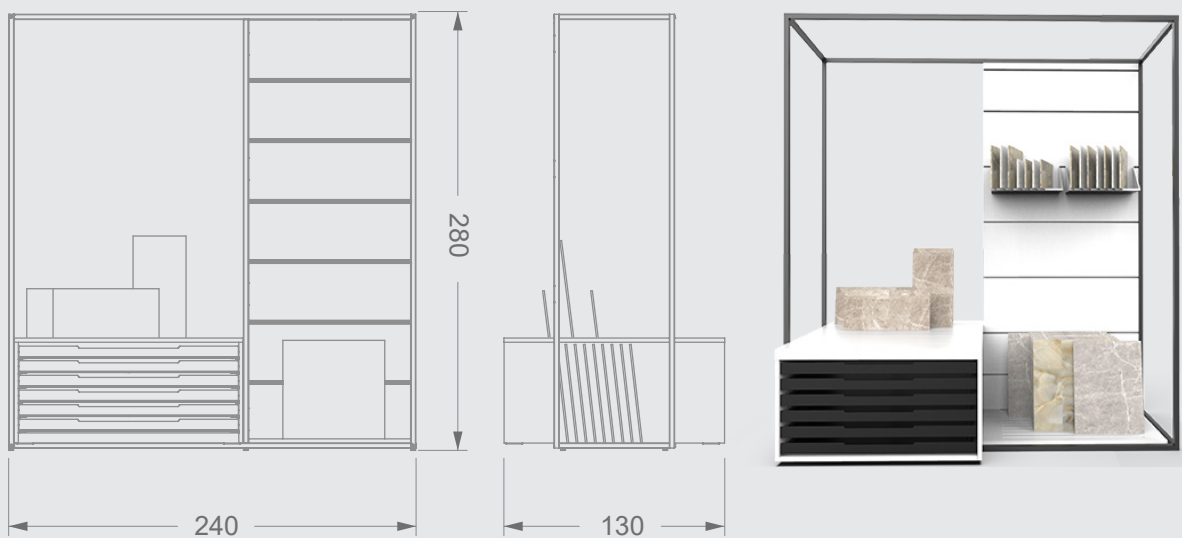

**BE002V75**

STAND

- 240x280x71 cm frame
- OSB wall and flooring for tile covering
- LED lightening system
- Raw chipboard/laminated chipboard,
- Raw MDF/MDFLAM optional



**BE002V76****STAND**

- 275x280x84 cm frame
- OSB wall and flooring for tile covering
- MDFLAM technical wall with channel
- 60X60 cm cradles 8 panels
- Floor panel 121x60/60x60 cm
- LED lightening system

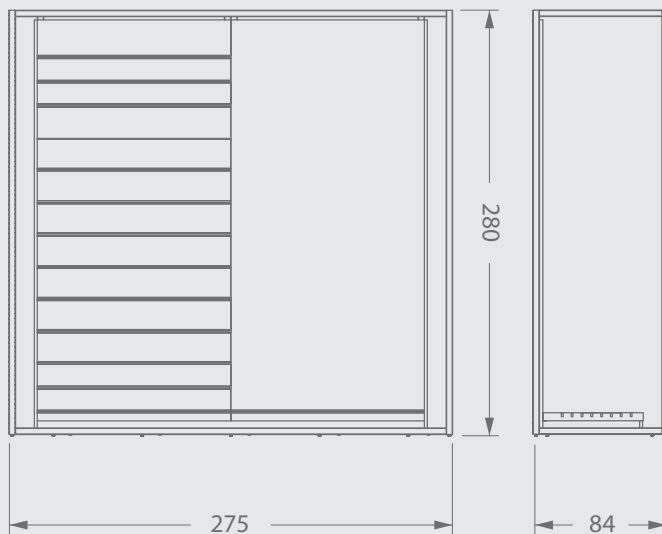

**BE002V77****STAND**

- 275x280x84 cm frame
- OSB wall and flooring for tile covering
- 60X60/120x120/60x120 cm cradles
- LED lightening system

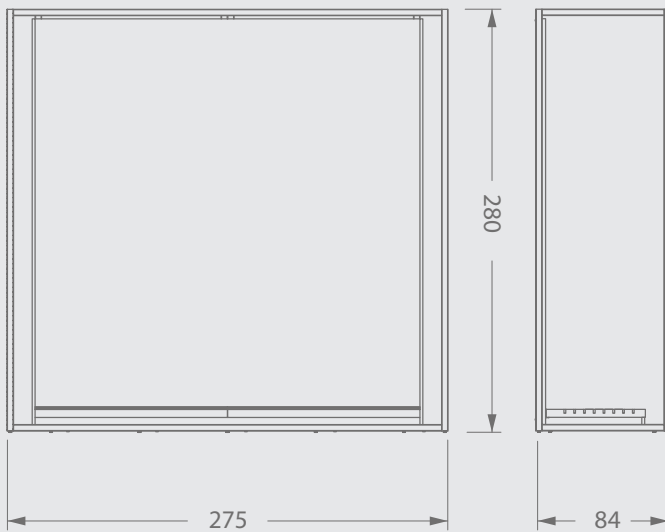

**BE002V78**

STAND

- 240x280x240 cm frame
- OSB wall and flooring for tile covering
- Raw chipboard/laminated chipboard,
- Raw MDF/MDFLAM optional

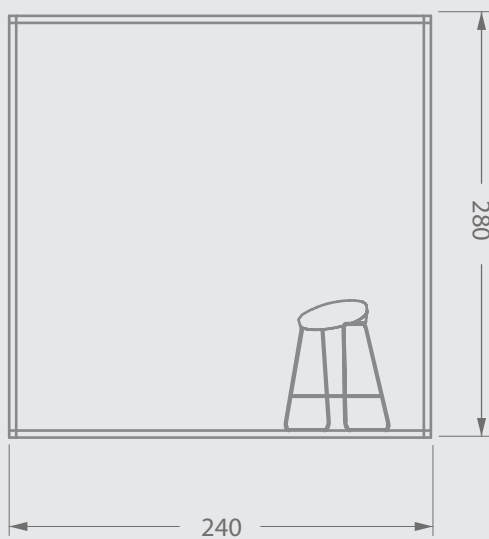

**BE002V79****STAND**

- 275x280x190 cm frame
- OSB wall and flooring for tile covering
- LED lightening system
- For tiles, wood, visuals or didactic panels
Raw chipboard/laminatedchipboard,
Raw MDF/MDFLAM optional

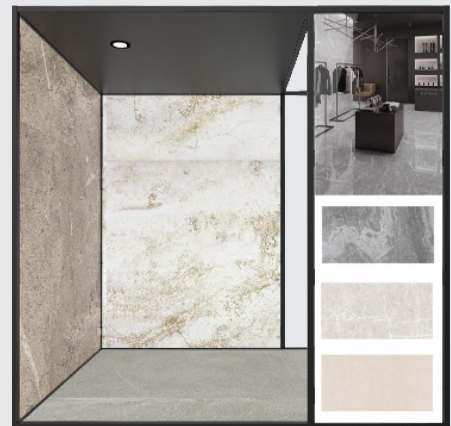
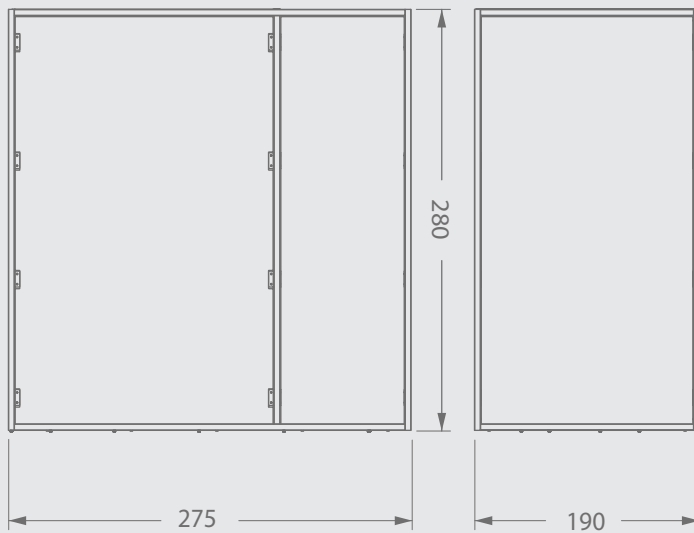

**BE002V80****STAND**

- 111x280x111 cm frame
- OSB wall and flooring for tile covering
- For tiles, wood, visuals or didactic panels
Raw chipboard/laminated chipboard,
Raw MDF/MDFLAM optional

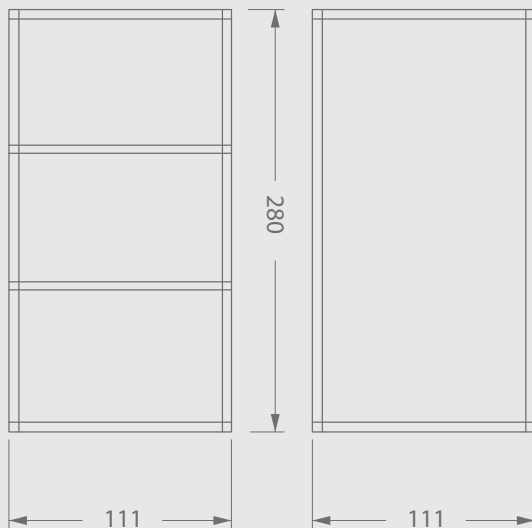



GN

consist of two main elements as skeleton frames and drawers. In many different sizes and sizes of products to be displayed or effective use of the area preserving the design integrity of the area.

which is designed with the aim of producing a more organic structure, exhibition areas provide effective use of space by preserving design integrity. Epsilon Series, which enables the presentation products such as ceramic, tile, stone, brick and shell product angular form. It is produced as completely disassembled without any material and can be easily installed.



GAMA-C

Model is a system where you can display armature and shelf products, can be adapted to any desired size and is demounted like all other Epsilon Series.

**BE003V43****TOTEM**

- 200x280x38 cm frame
- Available in different size

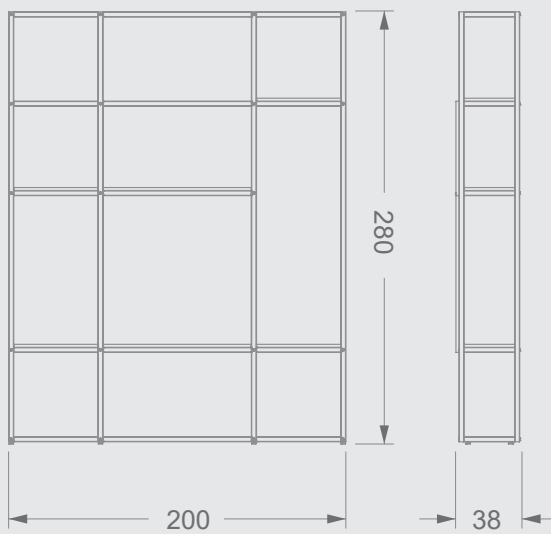

**BE003V02**

TABLE

- 280x280x44 cm frame
- Available in different size

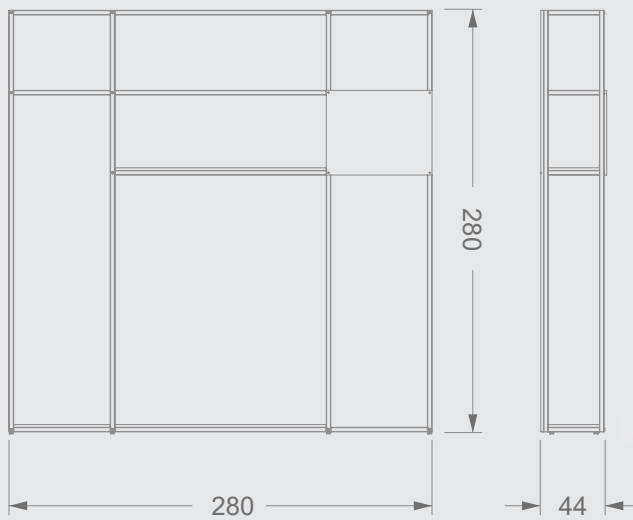

**BE003V44****TOTEM**

- 448x280x42 cm frame
- Available in different size

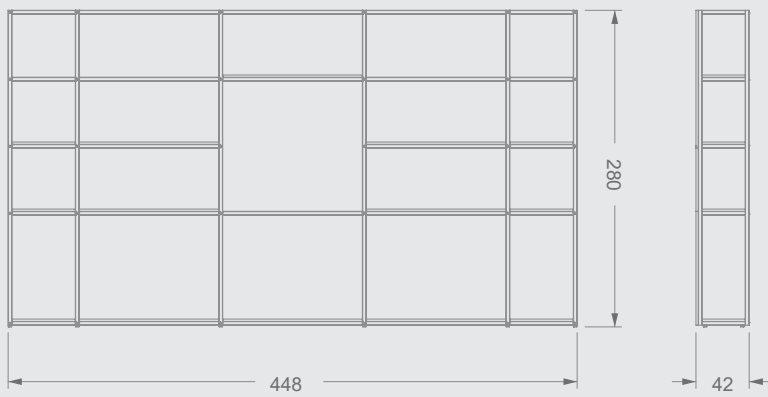

**BE003V04**

TABLE

- 507x280x64 cm frame
- Available in different size

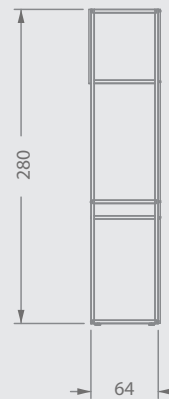
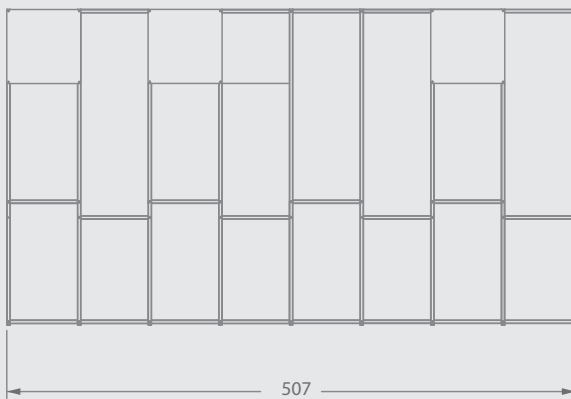

**BE030V01****TOTEM**

- 550x280x50 cm frame
- 360° rotating MDFLAM panels for accessories

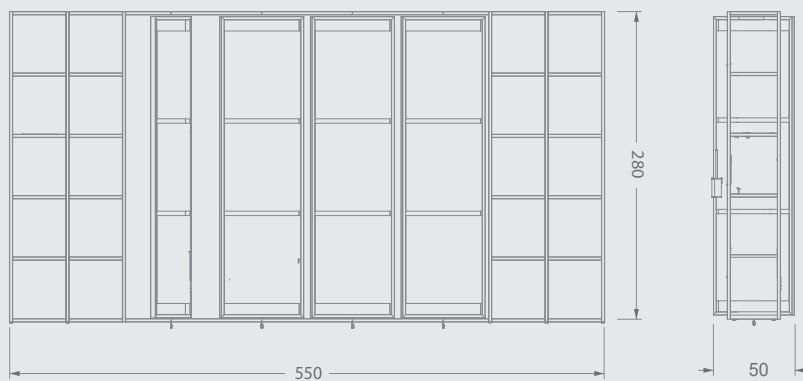

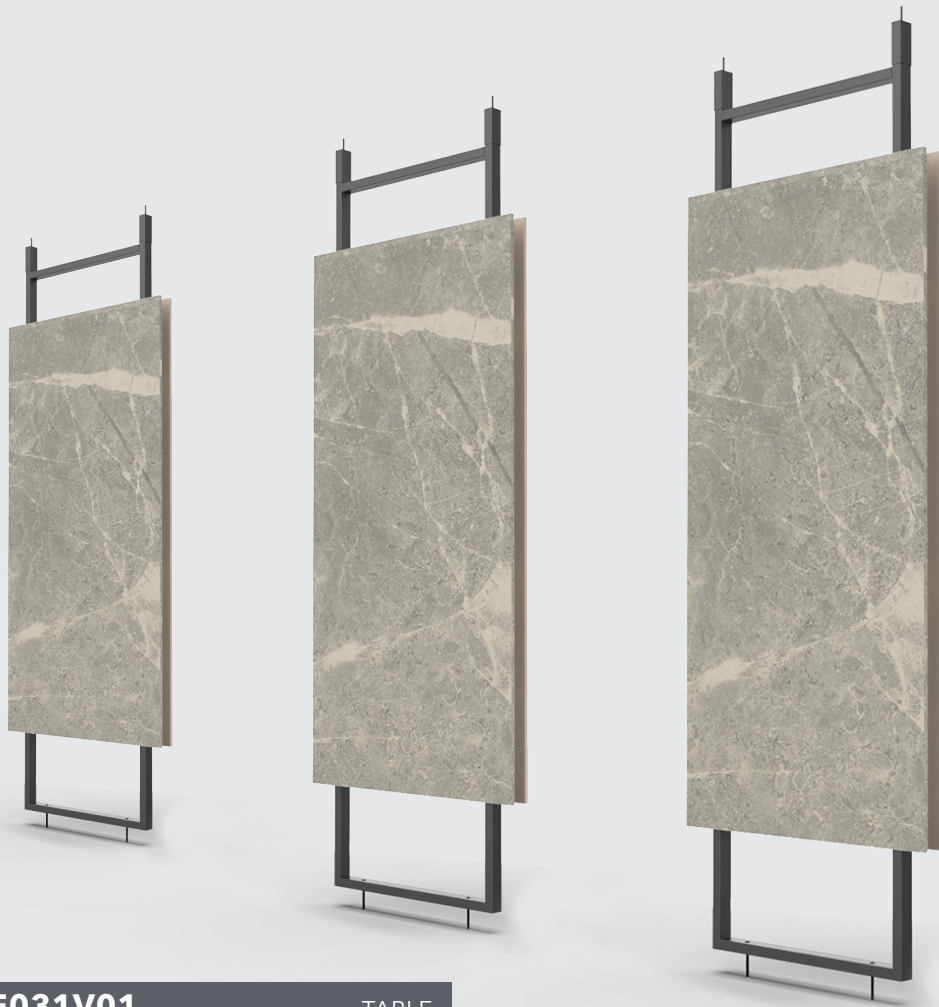
**BE031V01**

TABLE

- 95x330x6 cm frame
- For tiles from 120*240 height
- Adjustable frame for tiles of 100,120 or 160 cm

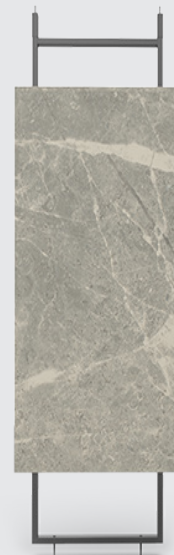
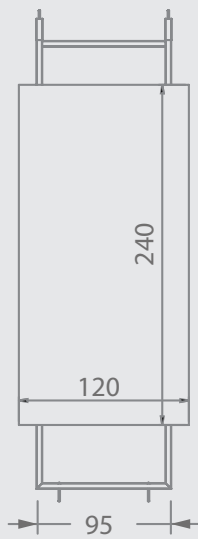

**BE030V05**

DESK

- 200x130x60 cm frame
- 4 pieces drawers

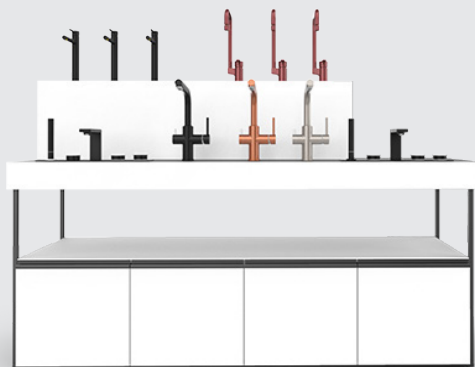
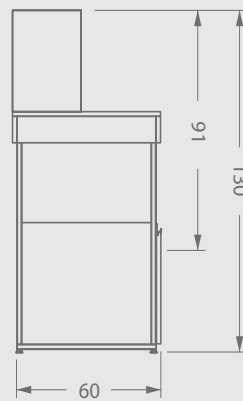
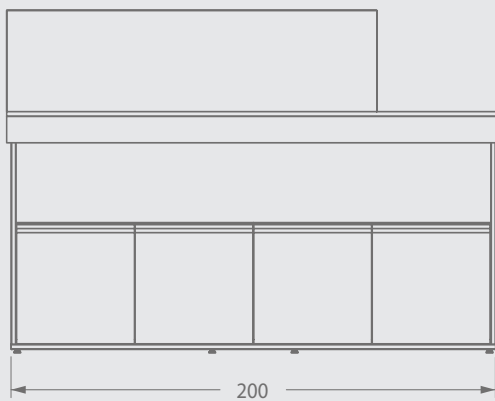

**BE030V03**

DESK

- 200x80x60 cm frame
- Available in different size

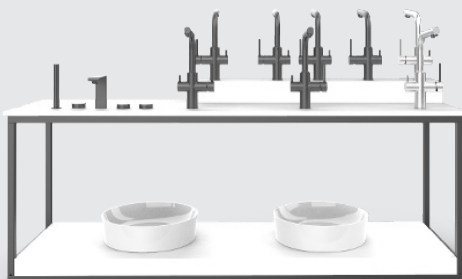
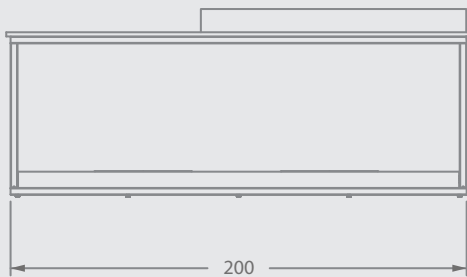

**BE030V06**

DESK

- 240x90x60 cm frame
- Available in different size

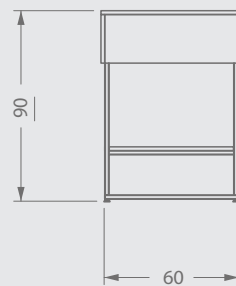
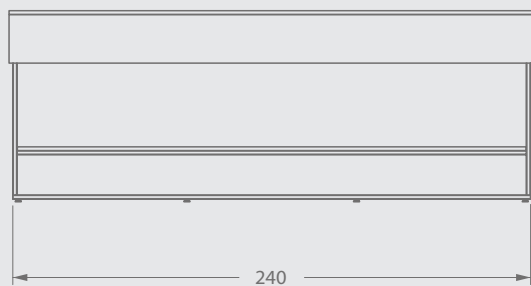

**BE030V07**

DESK

- 240x90x60 cm frame
- Available in different size

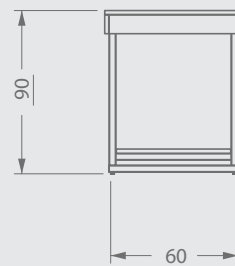
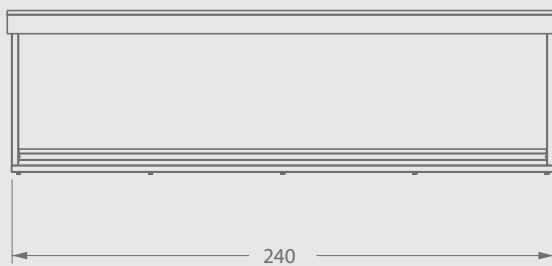

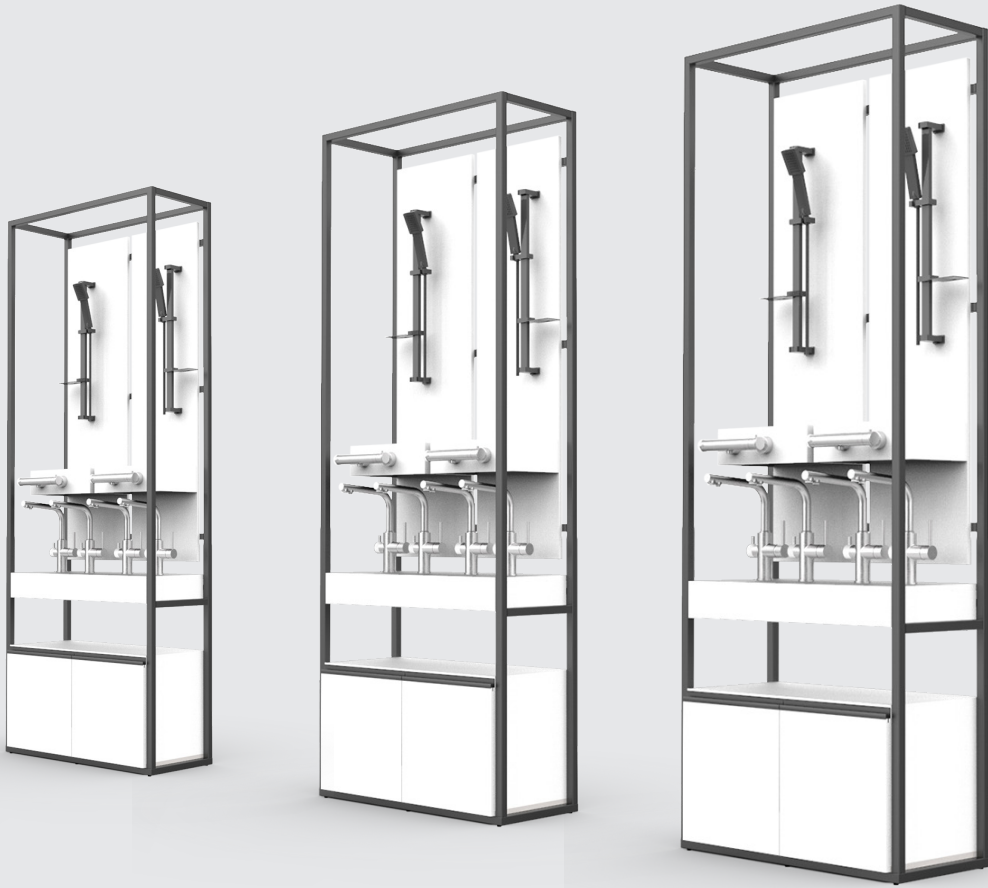
**BE030V31****TOTEM**

- 100x280x42 cm frame
- 2 pieces drawer

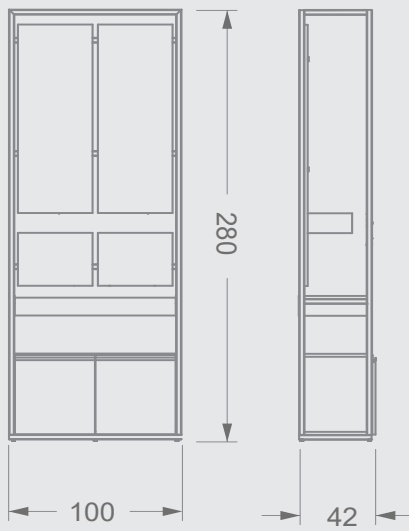

**BE030V08**

CRADLE

- 125x25x50 cm frame
- 60*60 cm cradles 5*2 panels

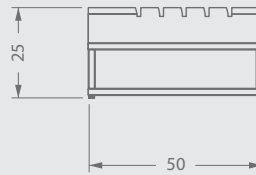
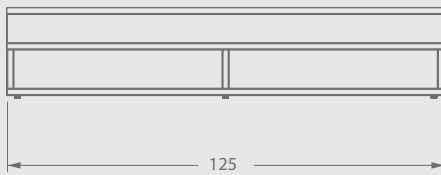

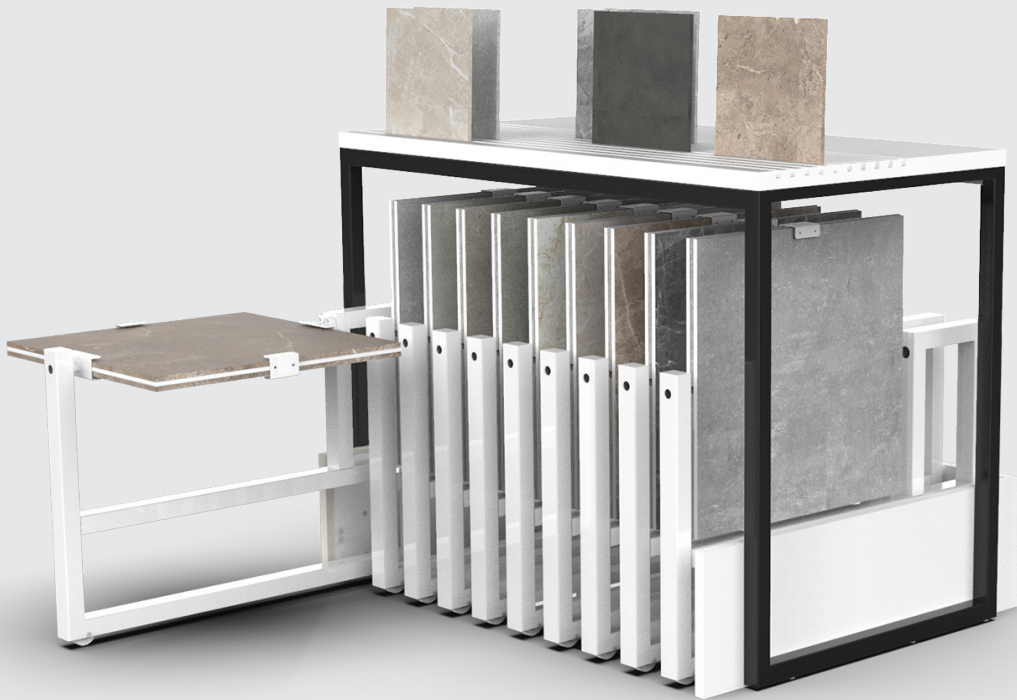
**BE030V09**

TABLE

- 135x103x96 cm frame
- 10x2 panels 60x60 cm pulling
- Top cradles 10 grooves

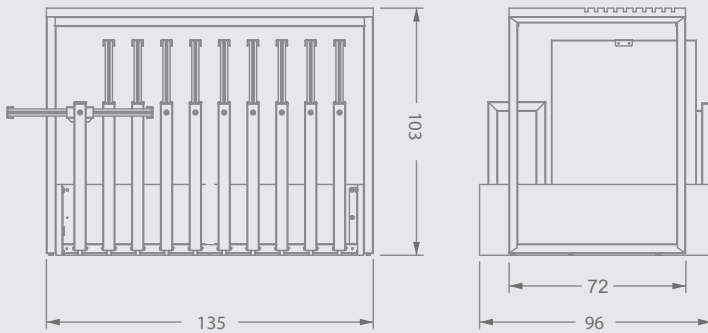



boracelik

ALL IN ONE
DISPLAY
SOLUTIONS

boracelik.com.tr

boracelik



TÜRKİYE

Organize Sanayi Bölgesi 21. Cadde No:41
Pk:26250 Eskişehir / Türkiye
T +90 222 236 19 40 **F** +90 222 236 19 41
E info@boracelik.com.tr

ITALY

Boracelik Italy S.r.l. Via del Crociale. 30. 41042
Spezzano di Fiorano Modenese (MO) Italy
T +39 0536 920519
E acorradi@boracelik.it

SPAIN

Avda Mediterraneo N120. Nave 3.12200
Onda (Castellon) Spain
T +34 626 965 787 / +34 964 626 260
E boracelikespana@boracelik.es

boracelik

ESKIŞEHİR TURKEY
CASTELLON SPAIN
SASSUOLO ITALY

EP
SIL
ON
Z
CA
TAL
ON
G